

ADJUSTMENT

1. REMOVE SIDE GARNISHES

Before making adjustments, remove the left and right side garnishes.

HINT:

After adjustment, reinstall the side garnishes.

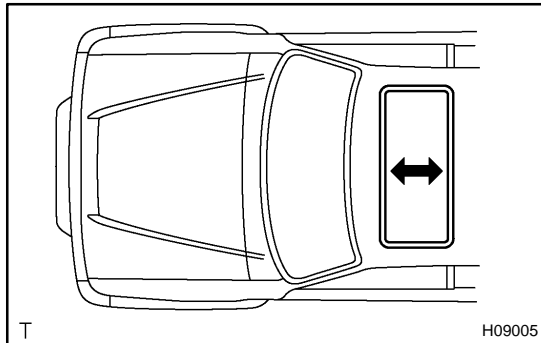

2. ADJUST FORWARD OR REARWARD

(a) Adjust by loosening the sliding roof installation nuts, and move the sliding roof bracket forward and backward.

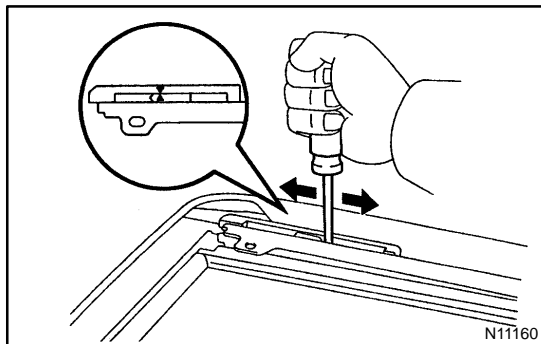

(b) When the front or rear alignment is not correct, remove the glass and adjust the drive rail.

(c) Using a screwdriver, slide the link forward or backward to align the 2 marks as shown.

(d) Slide the bracket to the forefront with your hand.

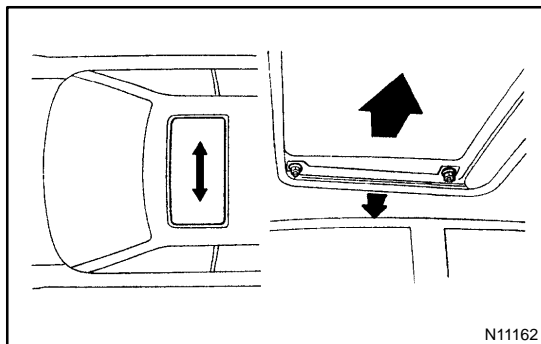

3. ADJUST RIGHT OR LEFT

Adjust by loosening the sliding roof rear shoe installation nuts, and move the sliding roof to the right and left.

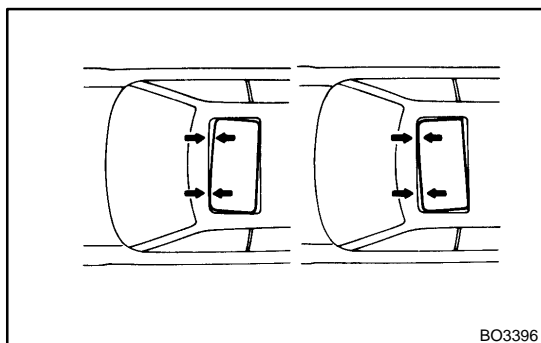

4. ADJUST CLEARANCE

(Difference in left and right clearance)

BODY - SLIDING ROOF

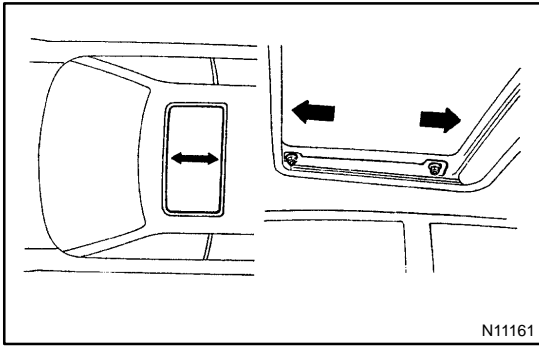

Adjust by loosening the sliding roof installation nuts and readjust the sliding roof to the proper position.