

INSTALLATION

Installation is in the reverse order of removal (See page BR-29).

1. AFTER INSTALLATION, FILL BRAKE RESERVOIR WITH BRAKE FLUID, BLEED BRAKE SYSTEM (See page BR-3)
2. CHECK FOR LEAKS

NOTICE:

Apply lithium soap base glycol grease and high temperature grease to the parts indicated by the arrows (See page BR-28).

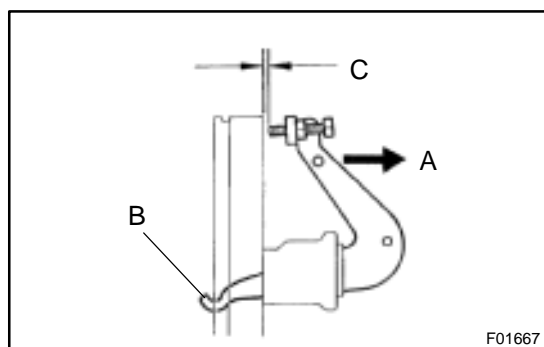

3. ADJUST BELLCRANK

- (a) Lightly pull the bellcrank in direction A until there is no slack at part B.
- (b) In this condition, turn the adjusting bolt so that dimension C will be 0.4 – 0.8 mm (0.016 – 0.031 in.).
- (c) Lock the adjusting bolt with the lock nut.
- (d) Connect the parking brake cable to the parking brake bellcrank and install the clip.
- (e) Install the tension spring.

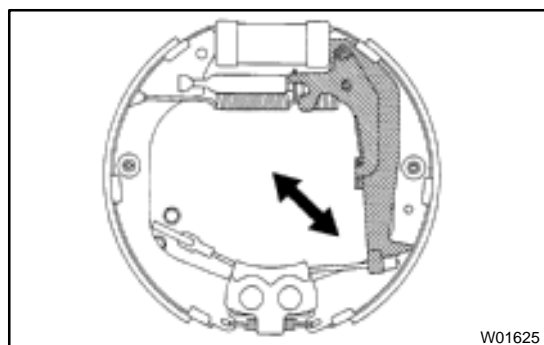

4. CHECK OPERATION OF AUTOMATIC ADJUSTING MECHANISM

- (a) Move the parking brake lever of the rear shoe back and forth, as shown. Check that the adjusting bolt turns.

If it does not turn, check for incorrect installation of the rear brakes.

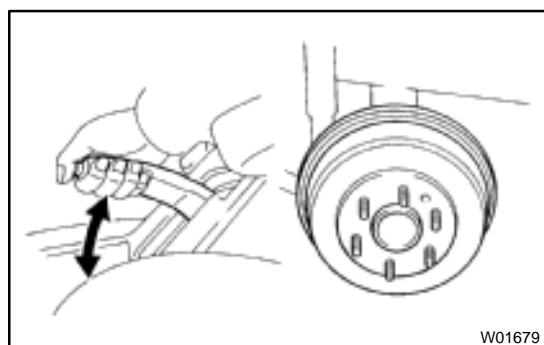

- (b) Adjust the adjuster length to the shortest possible amount.
- (c) Install the drum.
- (d) Pull the parking brake lever all the way up until a clicking sound can no longer be heard.

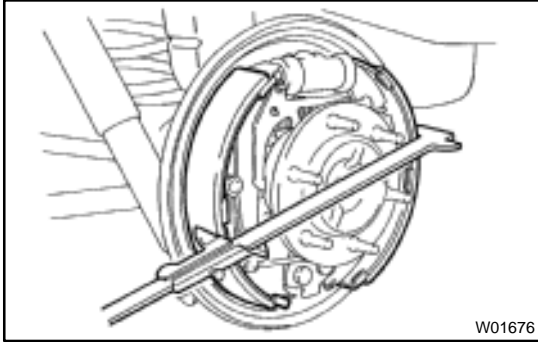

5. CHECK CLEARANCE BETWEEN BRAKE SHOES AND DRUM

- (a) Remove the drum.
- (b) Measure the brake drum inside diameter and diameter of the brake shoes. Check that the difference between the diameters is the correct shoe clearance.

Shoe clearance: 0.5 mm (0.020 in.)

If it is incorrect, check the parking brake system.

