

REAR AXLE SHAFT AND AXLE HUB (Double Tire)

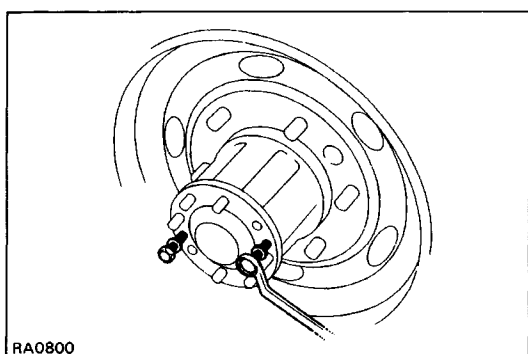
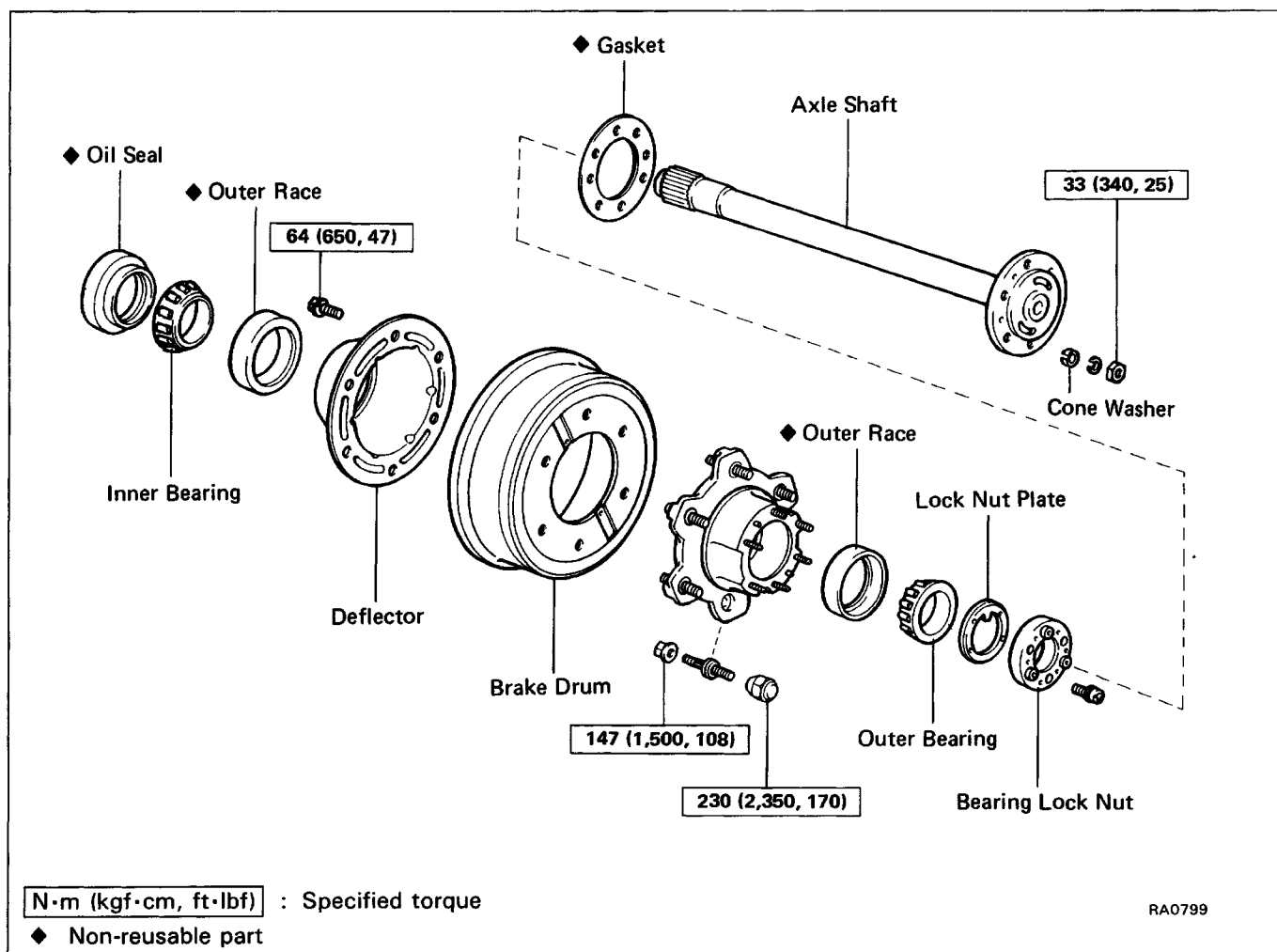

REMOVAL OF REAR AXLE SHAFT

1. REMOVE CONE WASHERS

- Remove the six nuts and washers.
- Install two service bolts and one turn.
- Tap on the shaft and remove the six cone washers.

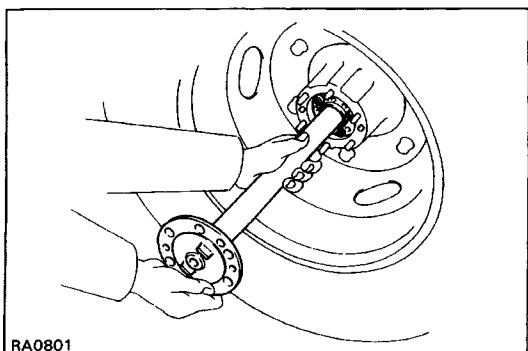

2. REMOVE REAR AXLE SHAFT

- Tighten the two service bolts and separate the axle shaft.
 - Remove the axle shaft with the gasket.
 - Remove the two service bolts.
- HINT: Be careful not to damage the oil seal with the splines.

INSPECTION OF REAR AXLE SHAFT COMPONENTS

1. INSPECT REAR AXLE SHAFT

Check for wear, damage or runout.

Maximum runout: 2.0 mm (0.079 in.)

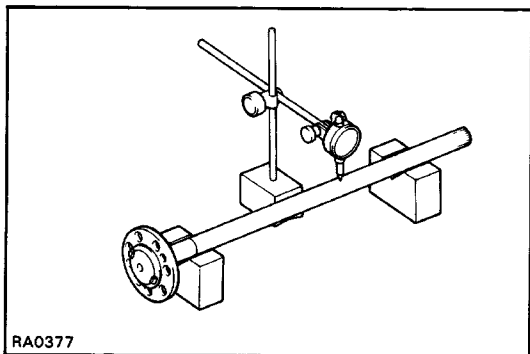

RA0377

2. INSPECT OIL SEAL FOR WEAR OR DAMAGE

If the oil seal is damaged or worn, replace it.

3. REPLACE OIL SEAL

(a) Using SST, remove the oil seal.

SST 09308-00010

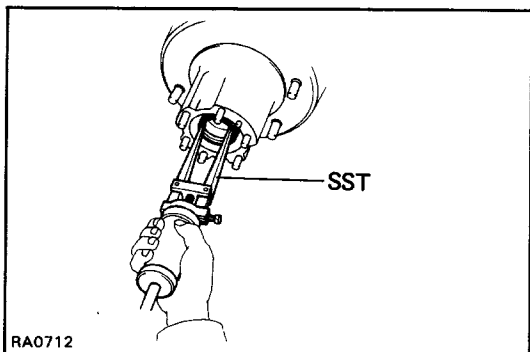

RA0712

(b) Using SST, drive in the oil seal.

SST 09517-12010

(c) Apply MP grease to the oil seal lip.

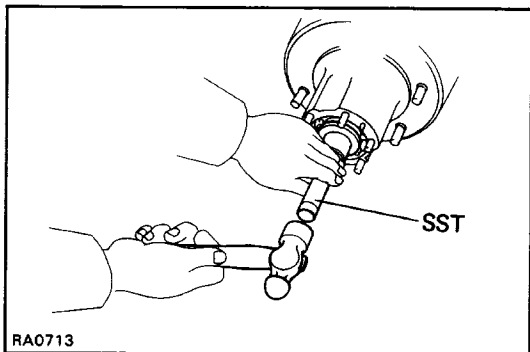

RA0713

INSTALLATION OF REAR AXLE SHAFT

(See page SA-127)

1. APPLY MP GREASE TO OIL SEAL LIP

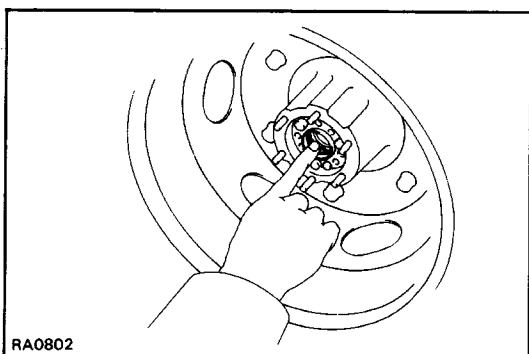

RA0802

2. INSTALL REAR AXLE SHAFT

Install the rear axle shaft, six cone washers and spring washers with nuts.

Torque: 33 N-m (340 kgf-cm, 25 ft-lbf)

HINT: Be careful not to damage the oil seal with the splines.

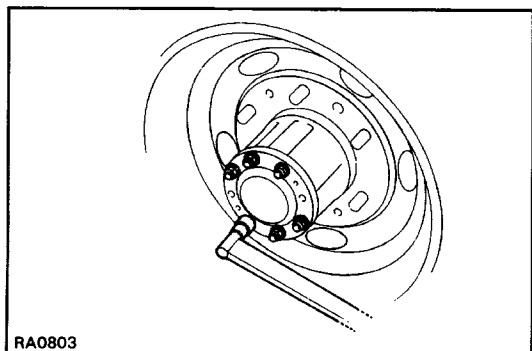

RA0803

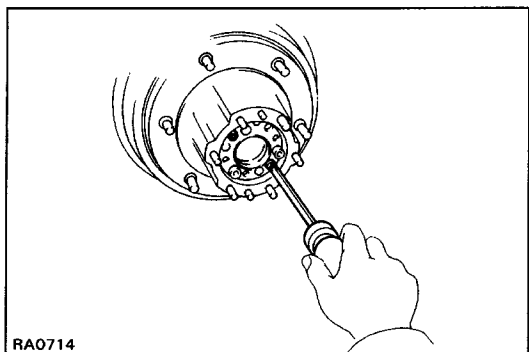

DISASSEMBLY OF REAR AXLE HUB

1. REMOVE REAR WHEEL AND REAR AXLE SHAFT

(See page SA-127)

2. REMOVE BEARING LOCK NUT

(a) Remove the two bolts from the bearing lock nut.

(b) Using SST, remove the bearing lock nut.

SST 09509-25011

(c) Remove the bearing lock plate.

3. REMOVE AXLE HUB FROM AXLE

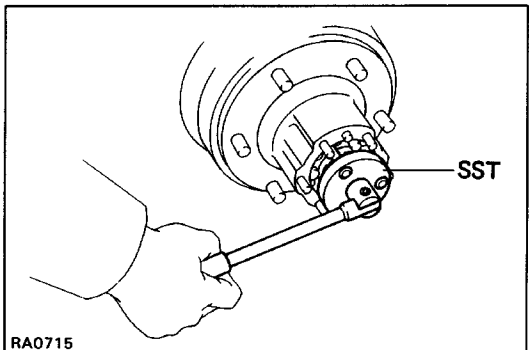

4. REMOVE OIL SEAL AND INNER BEARING

(a) Using SST, remove the oil seal from the axle hub.

SST 09308-00010

(b) Remove the inner bearing from the axle hub.

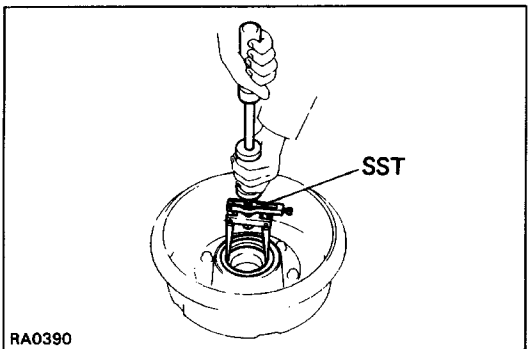

INSPECTION AND REPAIR OF REAR AXLE HUB

1. INSPECT AXLE HOUSING

Using a magnetic flaw detector or flaw detecting penetrant, check for damage or cracks.

2. REPLACE BEARING OUTER RACE

(a) Using a hammer and brass bar, drive out the outer race.

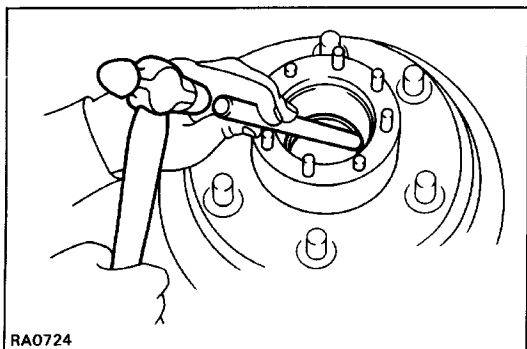

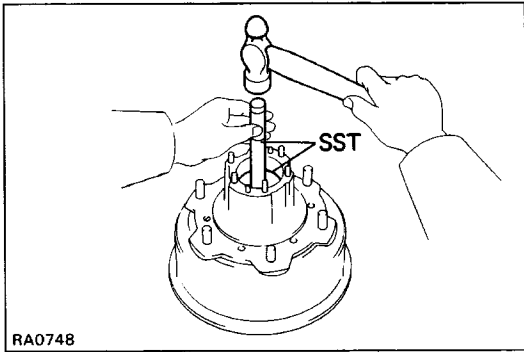

- (b) Using SST, carefully tap in a new bearing outer race.
 SST Inner side 09608-35014
 (09608-06020, 09608-06210)
 Outer side 09608-35014
 (09608-06020, 09608-06200)

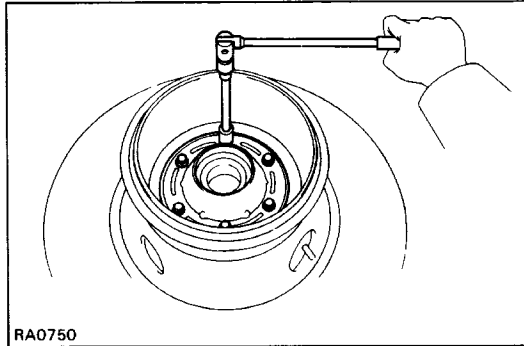

3. REPLACE HUB BOLT

- (a) Remove the six bolts and deflector.

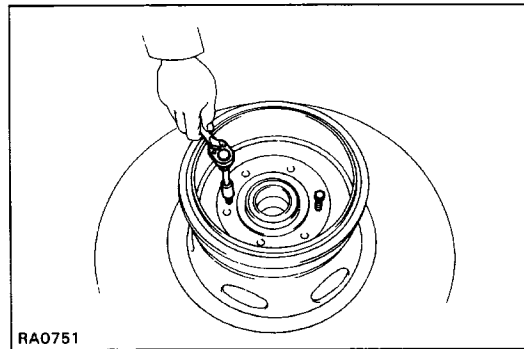

- (b) Using the two service bolts, separate the hub and brake drum.

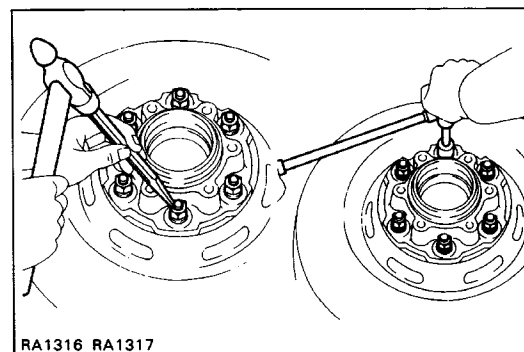

- (c) Unstake the bolt and remove the nut.

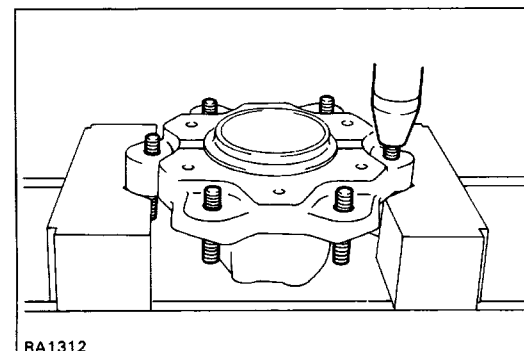

- (d) Using a press, press out the hub bolt.

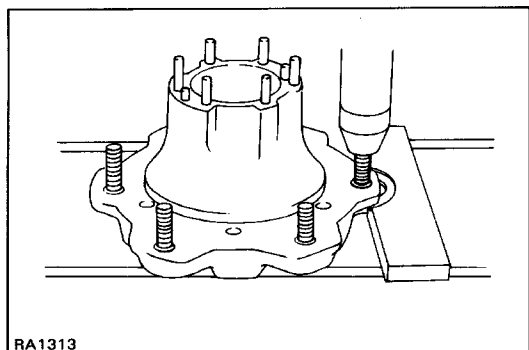

(e) Using a press, press in a new hub bolt.

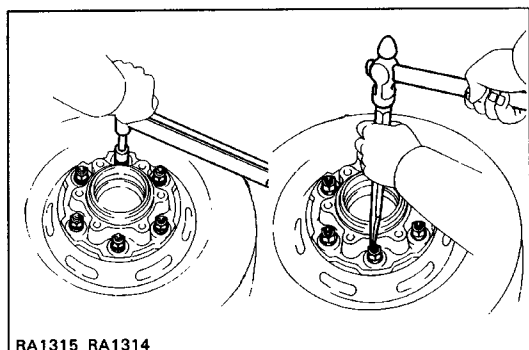

(f) Install and tighten the nut and stake the bolt.
Torque: 147 N-m (1,500 kgf-cm, 108 ft-lbf)

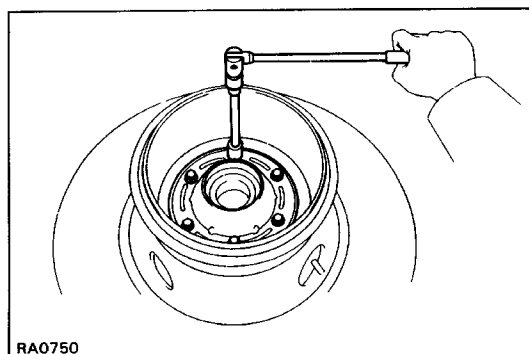

(g) Install the deflector and torque the six bolts.
Torque: 64 N-m (650 kgf-cm, 47 ft-lbf)

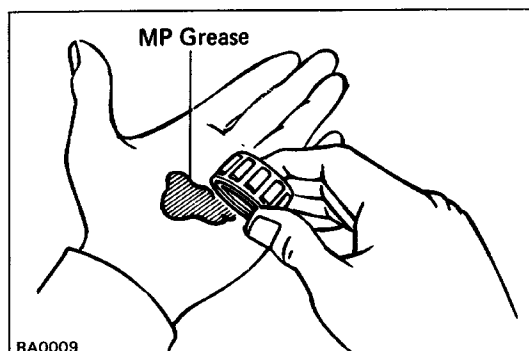

ASSEMBLY OF REAR AXLE HUB

(See page [SA-127](#))

1. PACK BEARING WITH MP GREASE

- Place MP grease in the palm of your hand.
- Pack grease into the bearing, and continuing until the grease oozes out from the other side.
- Do the same around the bearing circumference.

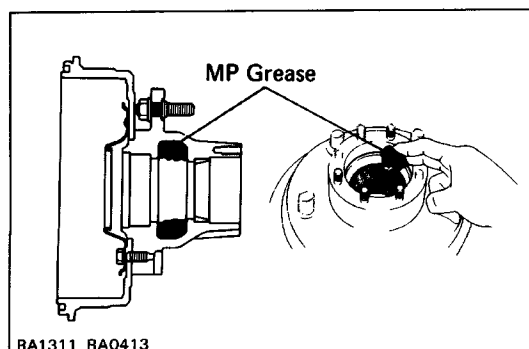

2. COAT SIDE HUB WITH MP GREASE

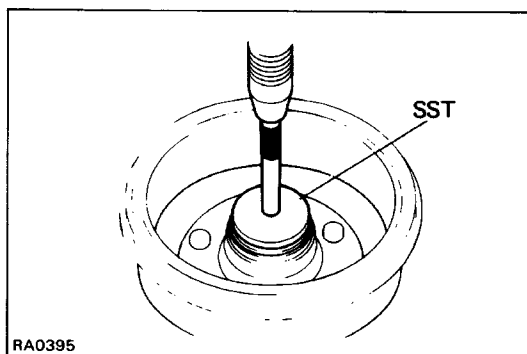

3. INSTALL INNER BEARING AND OIL SEAL

- (a) Place inner bearing into the hub.
- (b) Using SST, press in a new oil seal to the hub.
SST 09608-35014 (09608-06020 and 09608-06180)

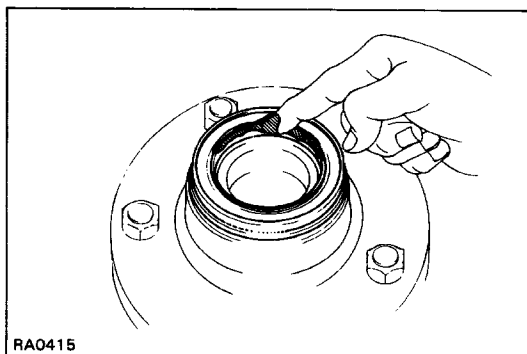

- (c) Apply MP grease to the oil seal lip.

4. INSTALL AXLE HUB ON AXLE HOUSING

- (a) Place the axle hub on the axle housing.
- (b) Install the outer bearing into the axle hub.

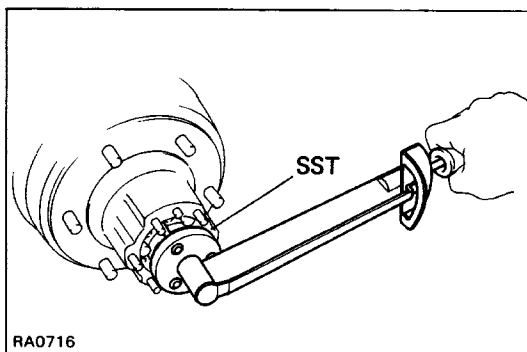

5. ADJUST PRELOAD

- (a) Install the lock plate.
- (b) Using SST, torque the bearing lock nut.
SST 09509-25011
Torque: 59 N-m (600 kgf-cm, 43 ft-lbf)

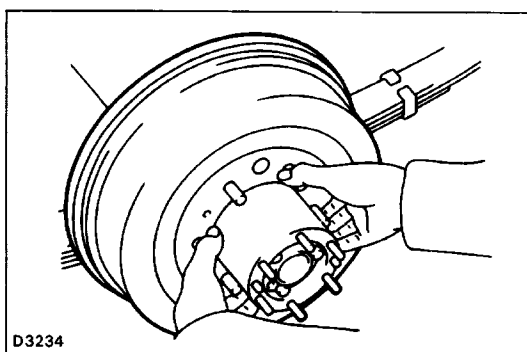

- (c) Snug down the bearing by turning the hub several times.

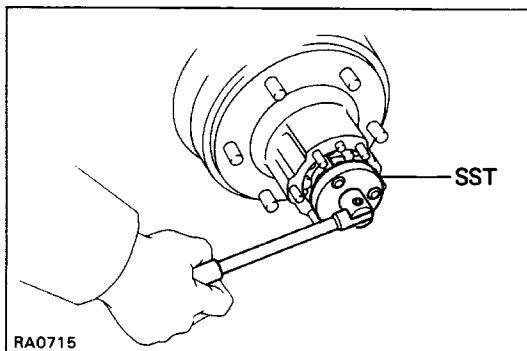

- (d) Using SST, retighten the bearing lock nut.
SST 09509-25011
Torque: 59 N-m (600 kgf-cm, 43 ft-lbf)
- (e) Using SST, loosen the bearing lock nut until you can rotate it by hand.
SST 09509-25011

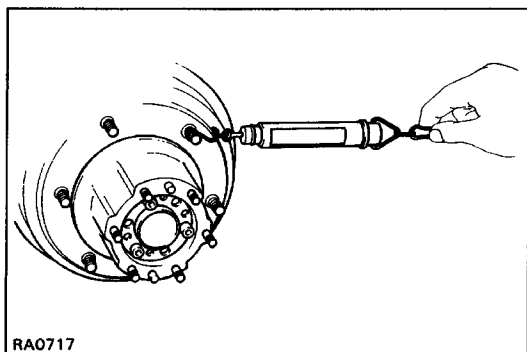

- (f) Using a spring tension gauge, measure and note friction force of the oil seal. (starting)
 (g) Using SST, tighten the bearing lock nut until the preload is within the specification below.
 SST 09 509-2 5011

Preload (starting):

Add oil seal frictional force

1.0 –14.7 N (0.1 –1.5 kgf, 0.2 –3.3 lbf)

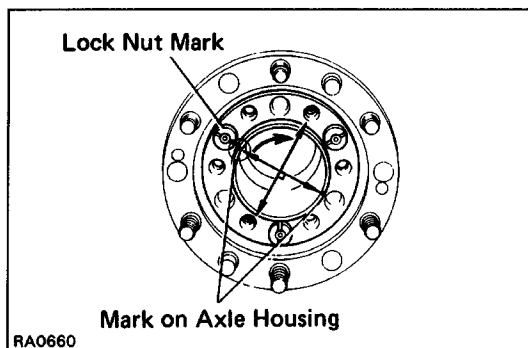

- (h) Align the lock nut mark with one of the marks on the axle housing, and place lock bolts in the holes at right angles to the lock nut.

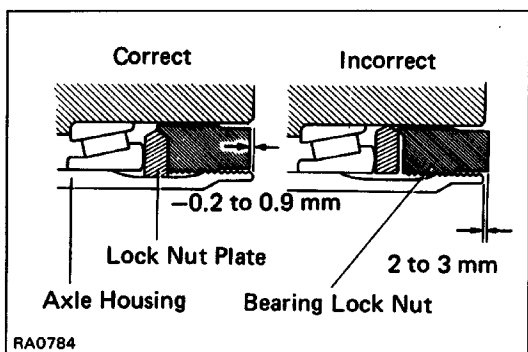

- (i) Measure the distance between the top surface of axle housing and the lock nut.
 Standard distance: - 0.2 to 0.9 mm
 (- 0.008 to 0.035 in.)
 If not within specification, reinstall the axle hub.

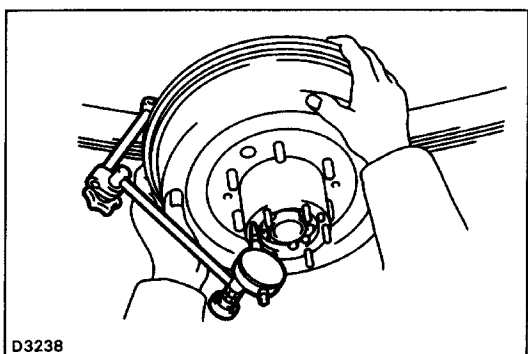

- (j) Check the movement of the drum.
 (k) Check that has no axle play.

6. INSTALL REAR AXLE SHAFT

(See page SA-128)

7. INSTALL WHEEL AND LOWER VEHICLE