

TIMING CHAIN COMPONENTS

EG1VJ-01

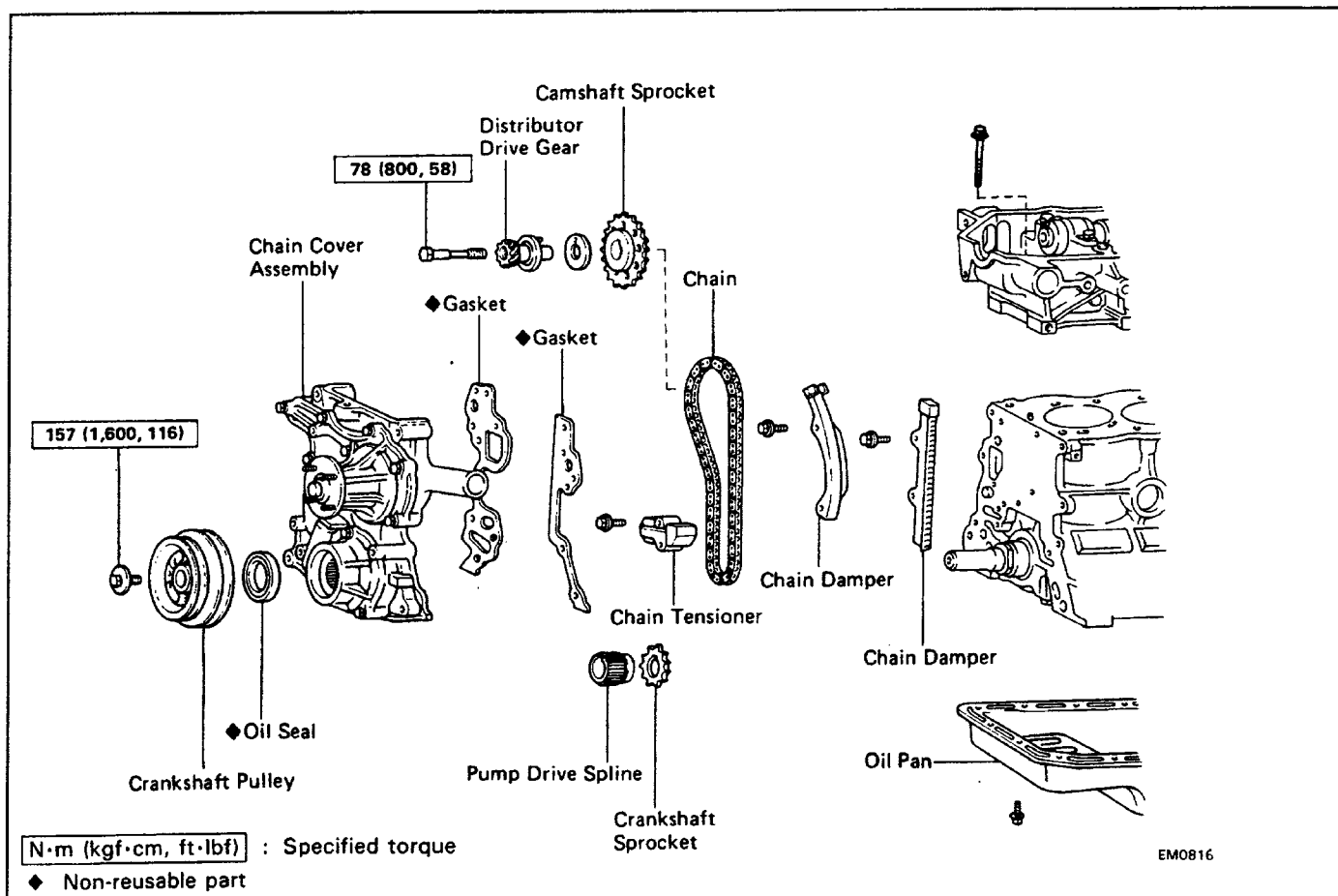

EG1VK-02

PREPARATION OF REMOVAL

1. REMOVE CYLINDER HEAD

(See page [EG1-16](#))

2. REMOVE RADIATOR

(See page [EG1-230](#))

3. (4WD)

REMOVE FRONT DIFFERENTIAL

(See SA section)

4. REMOVE OIL PAN

(a) Remove the engine undercover.

(b) Remove the engine mounting bolts.

(c) (2WD)

Place a jack under the transmission and raise the engine approx. 25 mm (0.98 in.)

(d) Remove the sixteen bolts and nuts.

(e) Using SST and brass bar, separate the oil pan from the cylinder block.

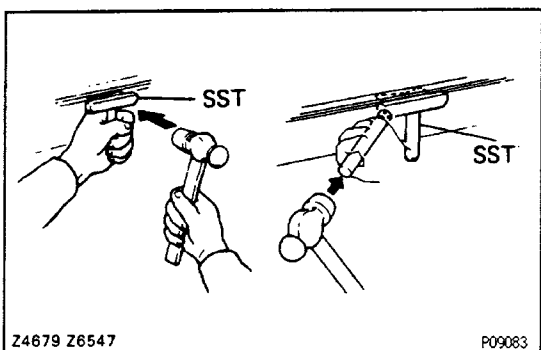

SST 09032 - 00100

HINT: When removing the oil pan, be careful not to damage the oil pan flange.

EG1VL-02

TIMING CHAIN REMOVAL

1. (W/PS)

REMOVE PS BELT

2. (with A/C)

REMOVE A/C BELT, COMPRESSOR AND BRACKET

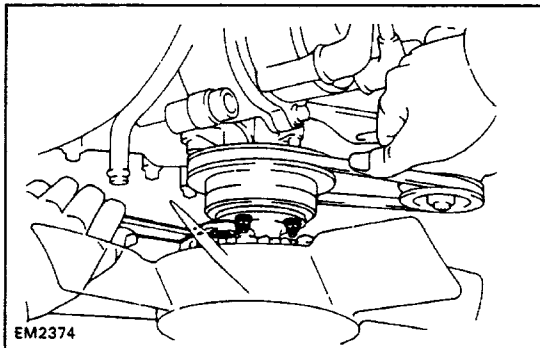

3. REMOVE FLUID COUPLING WITH FAN AND WATER PUMP PULLEY

- (a) Loosen the water pump pulley set bolts.
- (b) Loosen the belt adjusting bolt and pivot bolt of the generator, and remove the drive belt.
- (c) Remove the set nuts, fluid coupling with fan and water pump pulley.

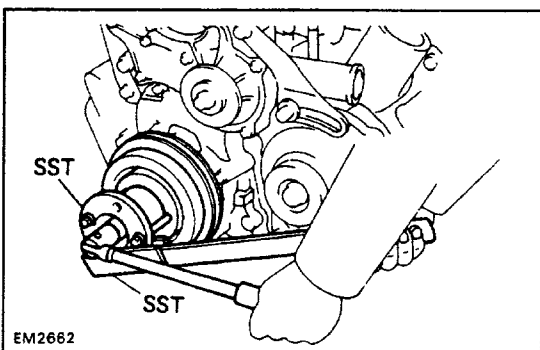

4. REMOVE CRANKSHAFT PULLEY

- (a) (with A/C (w/o Air pump) or w/PS (w/ Air pump))

Remove the No. 2 crankshaft pulley.

- (b) Using SST to hold the crankshaft pulley, loosen the pulley bolt.

SST 09213-70010 and 09330-00021

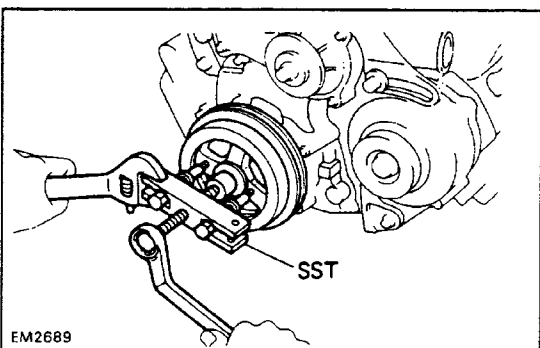

- (c) Using SST, remove the crankshaft pulley.

SST 09213-310231

HINT: If the front seal is to be replaced, see page

[EG1-236](#).

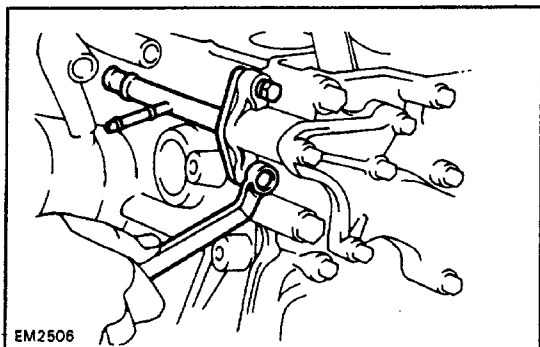
**5. REMOVE NO. 1 WATER BY-PASS PIPE**

Remove the two bolts and pipe.

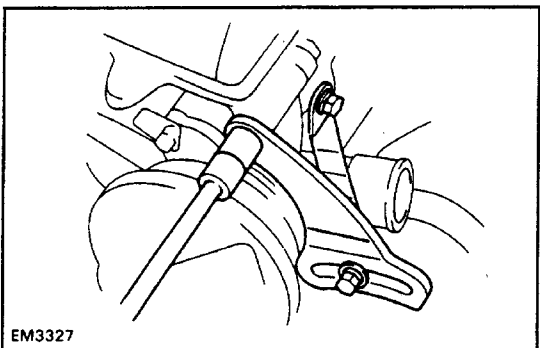
**6. REMOVE FAN BELT ADJUSTING BAR**

(a) (w/ PS)

Remove the bolt and PS lower bracket.

(b) Remove the three bolts and bar.

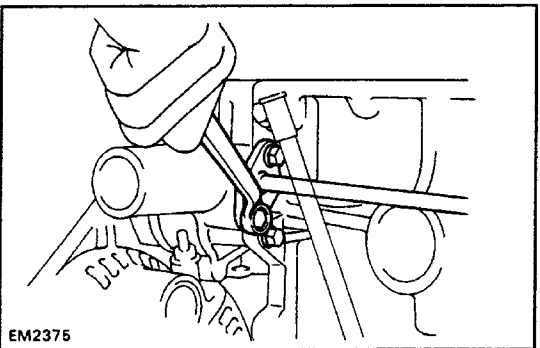
**7. DISCONNECT HEATER WATER OUTLET PIPE**

Remove the two bolts, and disconnect heater water outlet pipe.

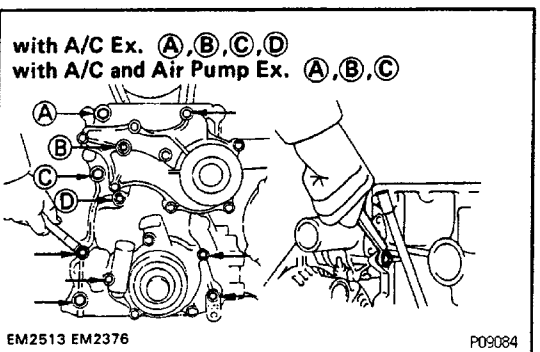
**8. REMOVE CHAIN COVER ASSEMBLY**

(a) Remove timing chain cover bolts shown by the arrows.

(b) Using a plastic faced hammer, loosen the chain cover and remove it.

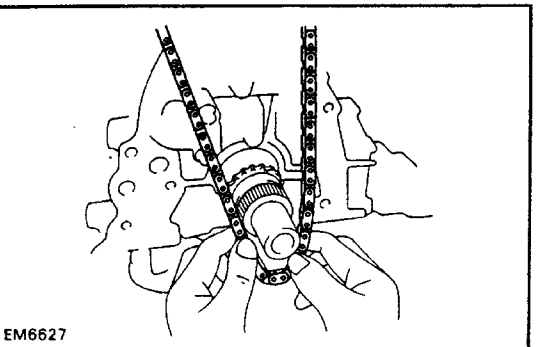
**9. REMOVE CHAIN AND CAMSHAFT SPROCKET**

(a) Remove the chain from the damper.

(b) Remove the cam sprocket and chain together.

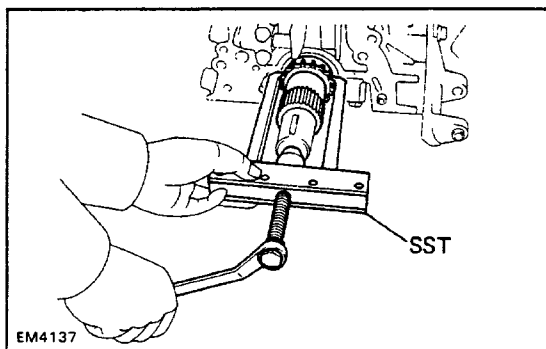

10. REMOVE PUMP DRIVE SPLINE AND CRANKSHAFT SPROCKET

If the oil pump drive spline and sprocket cannot be removed by hand, use SST to remove them together.
SST 09213-36020

11. REMOVE GASKET MATERIAL ON CYLINDER BLOCK

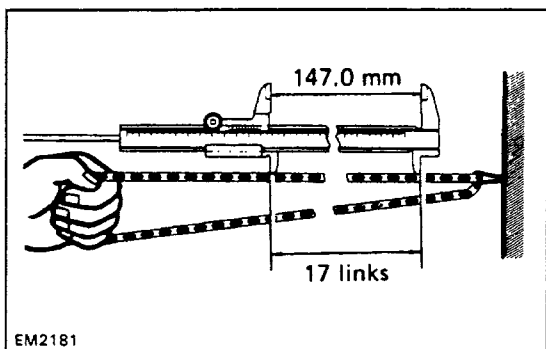

COMPONENTS INSPECTION

EG1VM-01

1. MEASURE CHAIN AND SPROCKET WEAR

(a) Measure the length of 17 links with the chain fully stretched.

(b) Make the same measurements at least three other places selected at random.

Chain elongation limit at 17 links: 147.0 mm (5.787 in.)

If over the limit at any one place the chain.

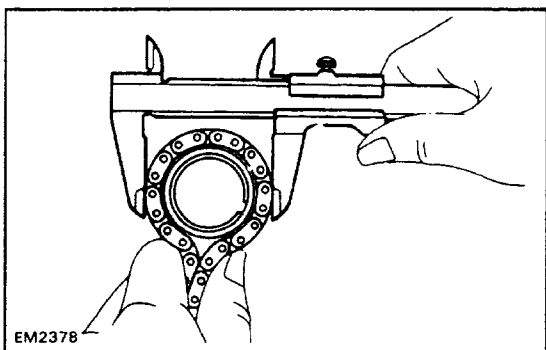

(c) Wrap the chain around the sprocket.

(d) Using a caliper gauge, measure the outer sides of the chain rollers as shown. Measure both sprockets.

Crankshaft sprocket minimum: 59.4 mm (2.339 in.)

Camshaft sprocket minimum: 113.8 mm (4.480 in.)

If the measurement is less than minimum, replace the chain and two sprockets.

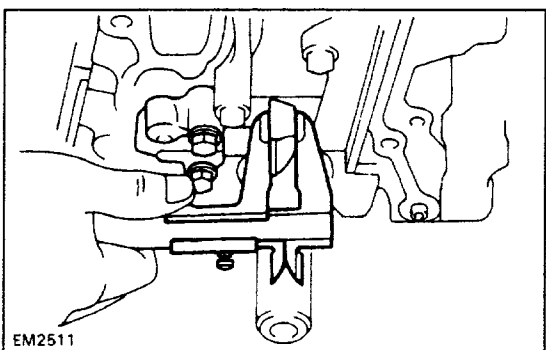

2. MEASURE CHAIN TENSIONER

Using a caliper gauge, measure the tensioner as shown.

Tensioner minimum: 11.0 mm (0.433 in.)

If the tensioner is worn or less than minimum, replace the chain tensioner.

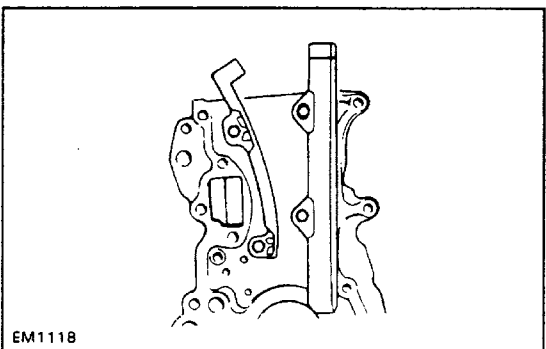

3. MEASURE CHAIN DAMPERS

Using a micrometer, measure each damper.

Damper wear limit: 0.5 mm (0.020 in.)

If either damper is worn or less than minimum, replace the damper.

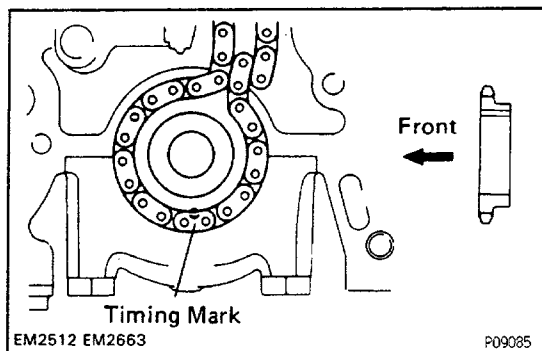

TIMING CHAIN INSTALLATION

(See page EG1-39)

1. INSTALL CRANKSHAFT SPROCKET AND CHAIN

- Turn the crankshaft until the shaft key is on top.
- Slide the sprocket over the key on the crankshaft.
- Place the timing chain on the sprocket with the single bright chain link aligned with the timing mark on the sprocket.

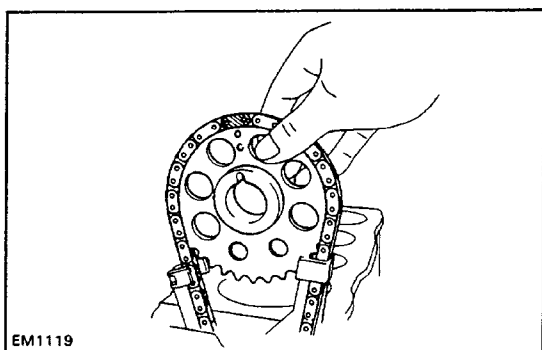

2. PLACE CHAIN ON CAMSHAFT SPROCKET

- Place the timing chain on the sprocket so that the bright chain link is aligned with the timing mark on the sprocket.
- Make sure the chain is positioned between the dampers.
- Turn the camshaft sprocket counterclockwise to take the slack out of the chain.

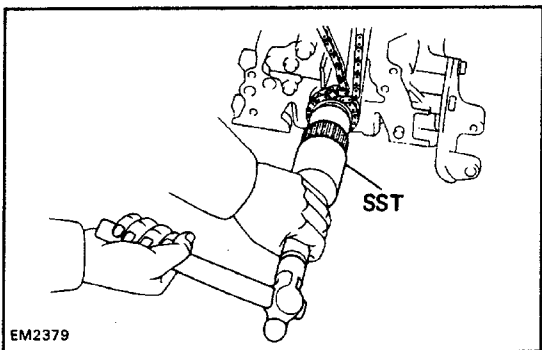

3. INSTALL OIL PUMP DRIVE SPLINE

Slide the oil pump drive spline over the crankshaft key.

HINT: If the oil pump drive spline is difficult to install by hand, install using SST.

SST 09608-35014 (09608-06040)

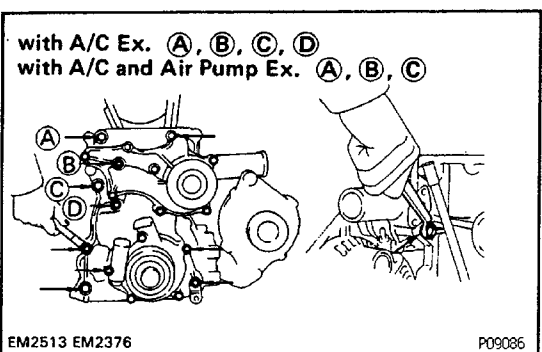

4. INSTALL TIMING CHAIN COVER ASSEMBLY

- Remove the old cover gaskets. Clean the gasket surface. Install new gaskets over the dowels.
- Slide the cover assembly over the dowels and pump spline.
- Insert the bolts as shown and torque them.

Torque: 8 mm bolt 13 N-m(130kgf-cm, 9ft-lbf)

10 mm bolt 13 N-m(400kgf-cm, 29ft-lbf)

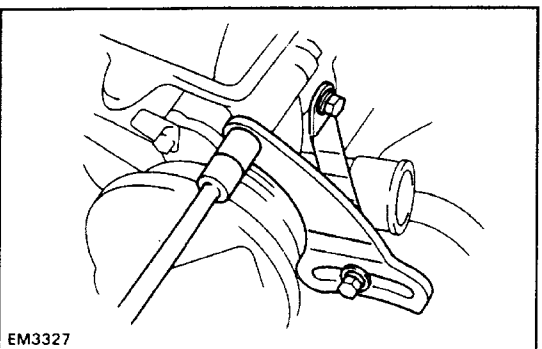

5. INSTALL FAN BELT ADJUSTING BAR

- Temporarily install the adjusting bar to the alternator.
- Install the adjusting bar to the chain cover and cylinder head.

Torque: 13N-m(130kgf-cm, 9ft-lbf)

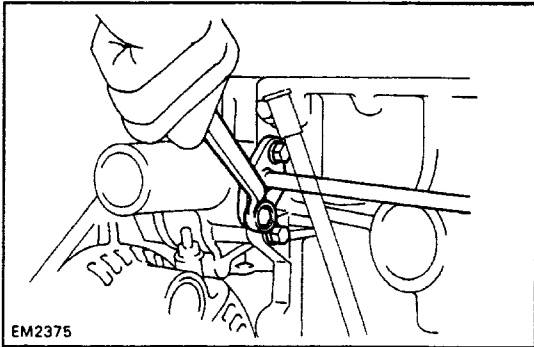
**6. INSTALL HEATER WATER OUTLET PIPE**

Connect the heater water outlet pipe to the timing chain cover with the two bolts.

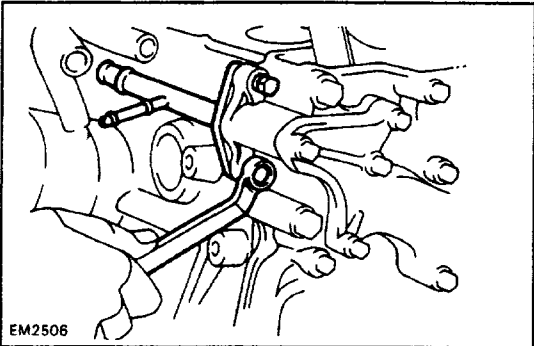
**7. INSTALL NO.1 WATER BY-PASS PIPE**

Install the pipe with the two bolts.

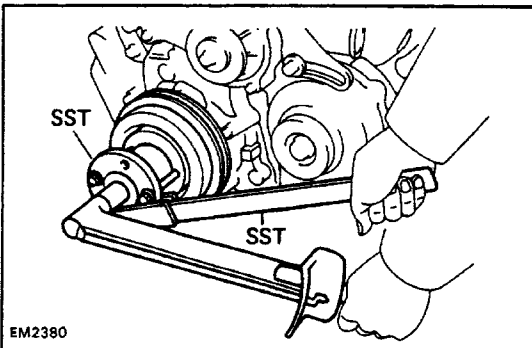
**8. INSTALL CRANKSHAFT PULLEY**

- (a) Install the crankshaft pulley and bolt.
- (b) Using SST to hole the crankshaft pulley, torque the bolt.

SST 09213-70010 and 09660-00021

Torque: 157N-m(1,600kgf-cm, 116ft-lbf)

- (c) (with A/C) Install the NO.2 crankshaft pulley.

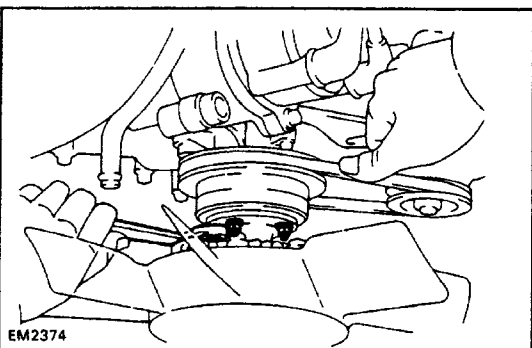
**9. INSTALL WATER PUMP PULLEY AND FLUID COUPLING WITH FAN**

- (a) Temporarily install the water pump pulley and fluid coupling with fan with the four nuts.
- (b) Place the drive belt onto each pulley.
- (c) Stretch the belt tight and tighten the four nuts.

10. ADJUST DRIVE BELT TENSION

(See page [MA-6](#))

11. (with A/C) INSTALL A/C COMPRESSOR BRACKET, COMPRESSOR AND BELT

(See page [MA-6](#))

12. (w/PS) INSTALL PS BELT

(See page [MA-6](#))

13. INSTALL OIL PAN

- (a) Remove any old packing material and be careful not to drop any oil on the contacting surfaces of the oil pan and cylinder block.

- Using a razor blade and gasket scraper, remove all the packing (FIPG) material from the gasket surfaces.
- Thoroughly clean all components to remove all the loose material.
- Clean both sealing surfaces with a non-residue solvent.

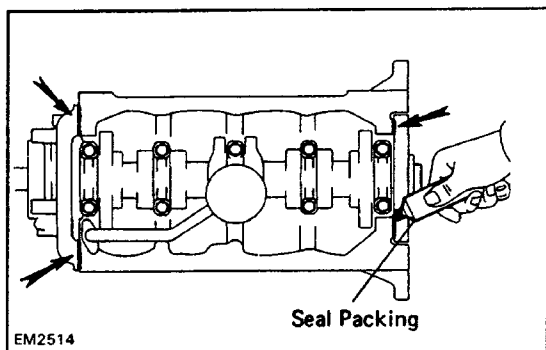

NOTICE: Do not use a solvent which will affect the painted surfaces.

(b) Apply seal packing to the joint part of the cylinder block and chain cover, cylinder block and rear oil seal retainer.

Seal packing: Part No.08826-00080 or equivalent

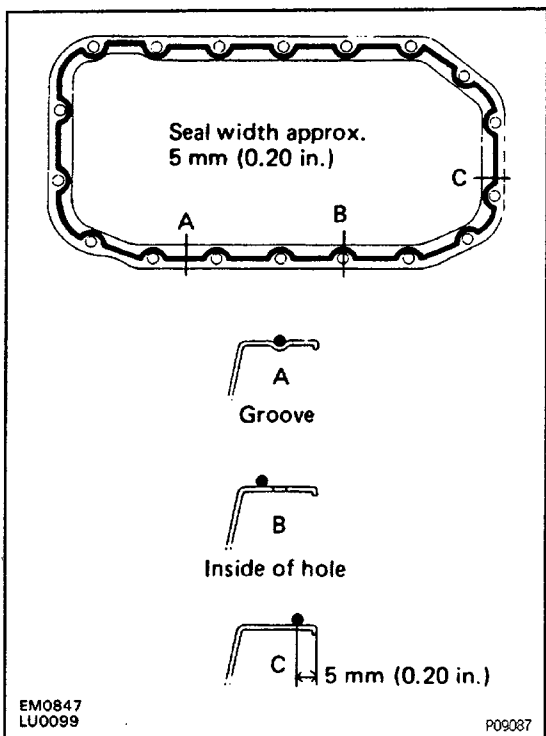

(c) Apply seal packing to the oil pan as shown in the illustration.

Seal packing: Part No.08826-00080 or equivalent

Install a nozzle that has been cut to a 5-mm (0.20 in.) opening.

HINT: Avoid applying an excess amount to the surface. Be especially careful near oil passages.

- If parts are not assembled within 5 minutes of applying the seal packing, the effectiveness of the seal packing is lost and the seal packing must be removed and reapplied.
- Immediately remove the nozzle from the tubs and reinstall the cap after using the seal packing.

(d) Install the oil pan over the studs on the block with the sixteen bolts and two nuts. Torque the bolts and nuts.

Torque: 13N-m(130kgf-cm, 9ft-lbf)

(e) Lower the engine and install the engine mounting bolts.

(f) Install the engine under cover.

POST INSTALLATION

1. INSTALL RADIATOR

2. INSTALL CYLINDER HEAD

(See page [EG1-34](#))

3. (4WD) INSTALL FRONT DIFFERENTIAL

(See SA section)