

IGNITION

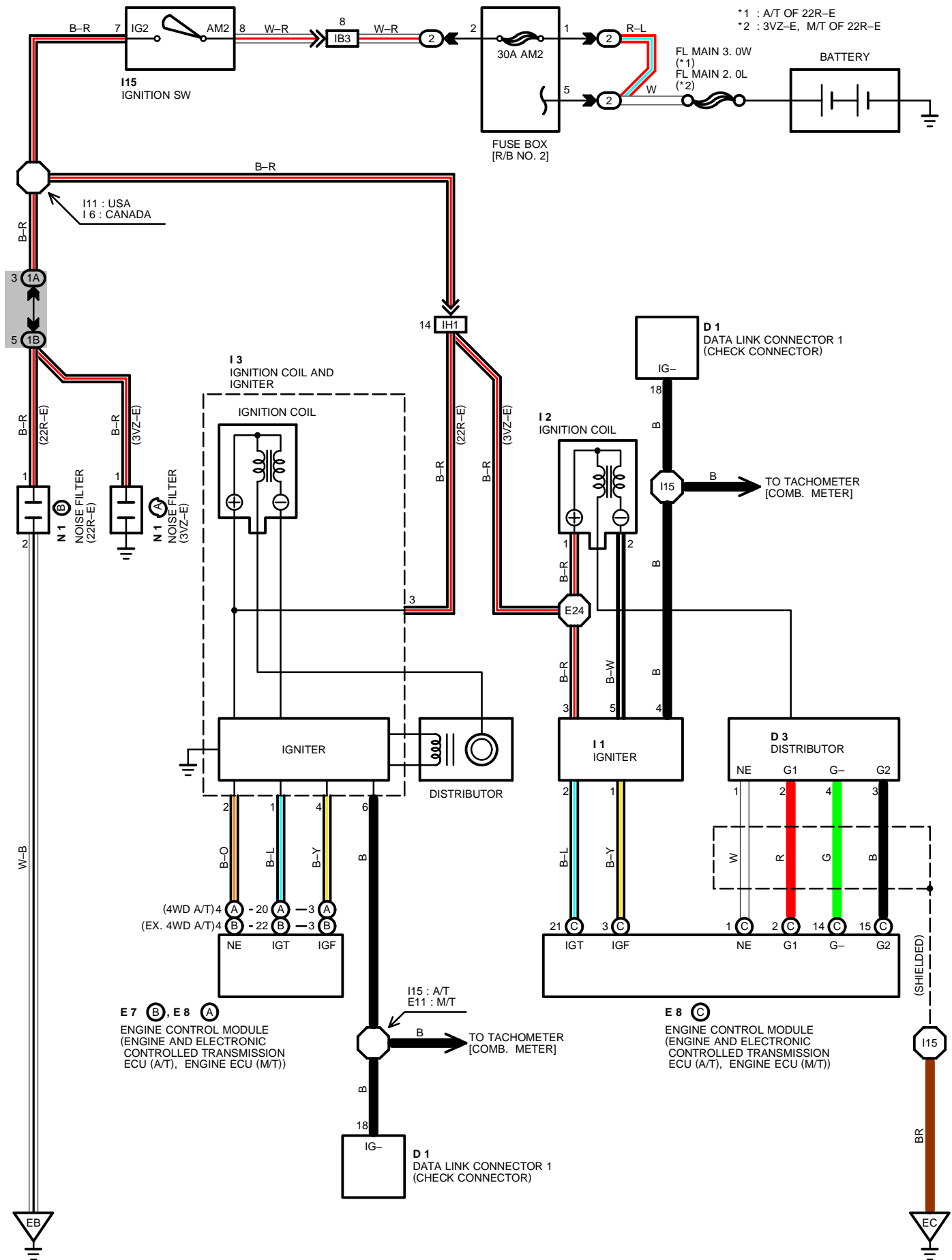

○ : PARTS LOCATION

CODE	SEE PAGE	CODE	SEE PAGE	CODE	SEE PAGE
D 1	24 (3VZ-E)	E 8	C 28	I15	28
D 3	24 (3VZ-E)	I 1	24 (3VZ-E)	N 1	A 25 (3VZ-E)
E 7	B 28	I 2	24 (3VZ-E)		B 27 (22R-E)
E 8	A 28	I 3	27 (22R-E)		

○ : RELAY BLOCKS

CODE	SEE PAGE	RELAY BLOCKS (RELAY BLOCK LOCATION)
2	22	R/B NO. 2 (ENGINE COMPARTMENT RIGHT)

○ : JUNCTION BLOCK AND WIRE HARNESS CONNECTOR

CODE	SEE PAGE	JUNCTION BLOCK AND WIRE HARNESS (CONNECTOR LOCATION)
1A	20	COWL WIRE AND J/B NO. 1 (LEFT KICK PANEL)
1B	20	ENGINE ROOM MAIN AND J/B NO. 1 (LEFT KICK PANEL)

□ : CONNECTOR JOINING WIRE HARNESS AND WIRE HARNESS

CODE	SEE PAGE	JOINING WIRE HARNESS AND WIRE HARNESS (CONNECTOR LOCATION)
IB3	34	ENGINE ROOM MAIN WIRE AND COWL WIRE
IH1	34	ENGINE WIRE AND COWL WIRE (RIGHT KICK PANEL)

▽ : GROUND POINTS

CODE	SEE PAGE	GROUND POINTS LOCATION
EB	32 (22R-E)	LEFT FENDER
EC	30 (3VZ-E)	CAMSHAFT BEARING CAP

○ : SPLICE POINTS

CODE	SEE PAGE	WIRE HARNESS WITH SPLICE POINTS	CODE	SEE PAGE	WIRE HARNESS WITH SPLICE POINTS
E11	32 (22R-E)	ENGINE WIRE	I11	34	COWL WIRE
E24	30 (3VZ-E)		I15	34	ENGINE WIRE
I 6	34	COWL WIRE			

