

TIMING BELT COMPONENTS

EG1E5-02

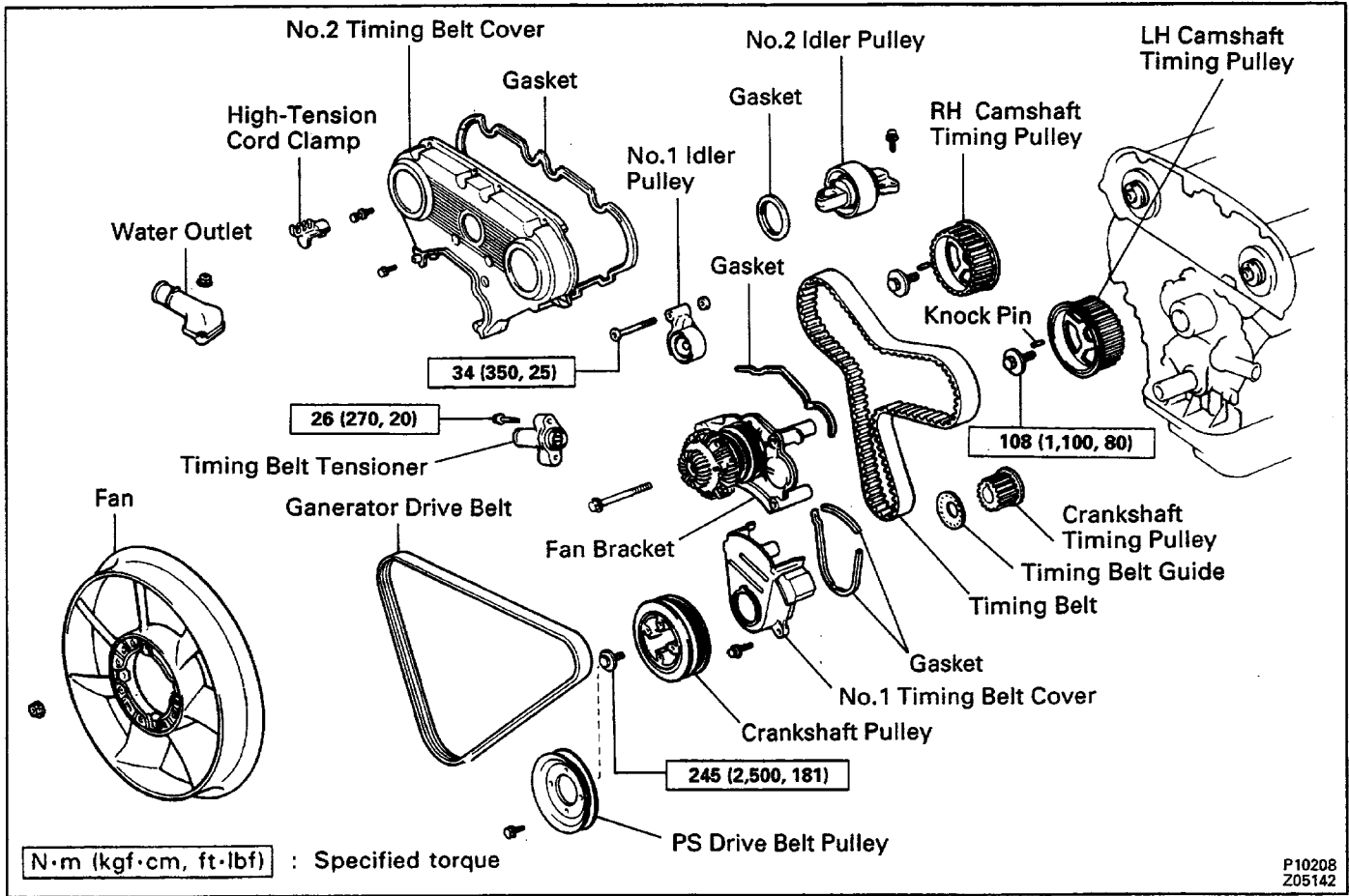

EG205-01

TIMING BELT REMOVAL

(See Components)

NOTICE: If removing and later reinstalling the fluid coupling from the fan bracket, place matchmarks on the fluid coupling and fan bracket so that the fluid coupling can be replaced exactly as before.

1. DISCONNECT CABLE FROM NEGATIVE TERMINAL OF BATTERY

2. REMOVE ENGINE UNDER COVER

3. DRAIN ENGINE COOLANT

4. REMOVE RADIATOR

(a) Disconnect the reservoir hose.

(b) (A/T only)

Disconnect the oil cooler hoses.

(c) Remove the radiator hoses.

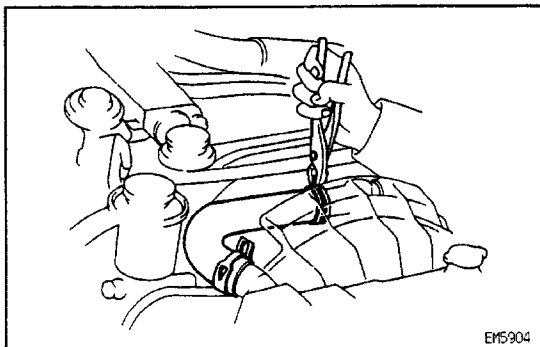
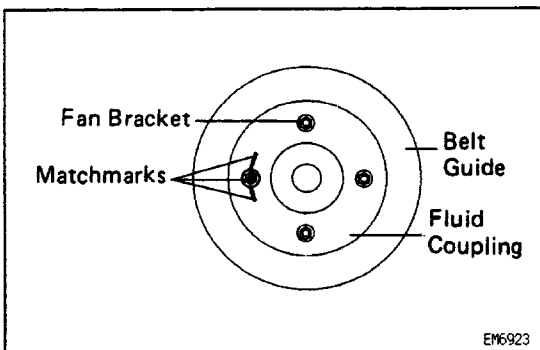

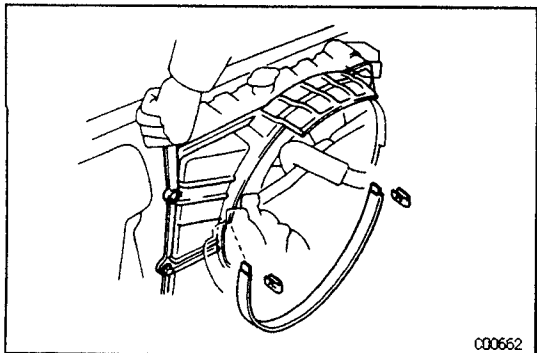

- (d) Remove the two clips and No.2 fan shroud.
- (e) Remove the four bolts and No.1 fan shroud.
- (f) Remove the four bolts and radiator.

5. DISCONNECT NO.2 AND NO.3 AIR HOSES FROM AIR PIPE

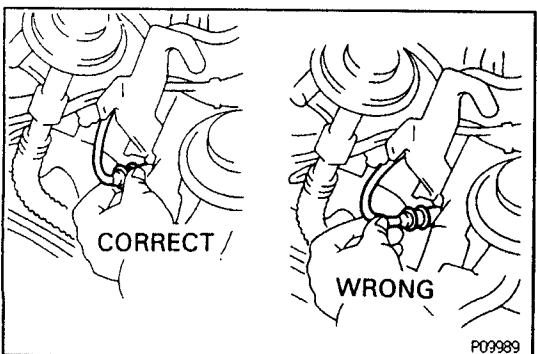

6. DISCONNECT HIGH-TENSION CORDS FROM SPARK PLUGS

Disconnect the high - tension cords at the rubber boot. Do not pull on the cords.

NOTICE: Pulling on or bending the cords may damage the conductor inside.

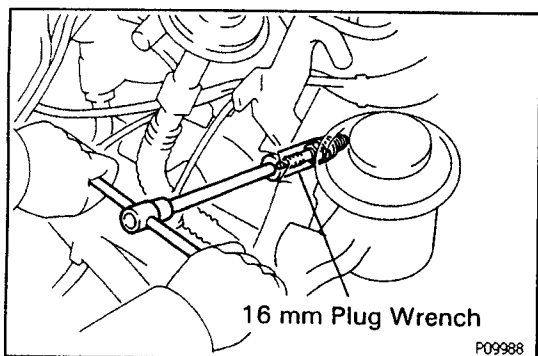

7. REMOVE SPARK PLUGS

Using a 16 mm plug wrench, remove the six spark plugs.

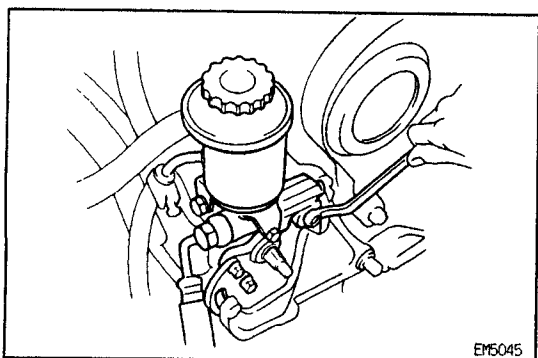

8. REMOVE PS DRIVE BELT AND PUMP PULLEY

9. DISCONNECT PS PUMP FROM ENGINE

10. REMOVE A/C DRIVE BELT

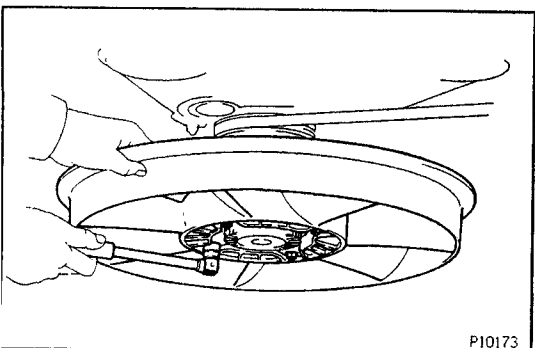

11. REMOVE COOLING FAN

Remove the four nuts and cooling fan.

12. REMOVE GENERATOR DRIVE BELT

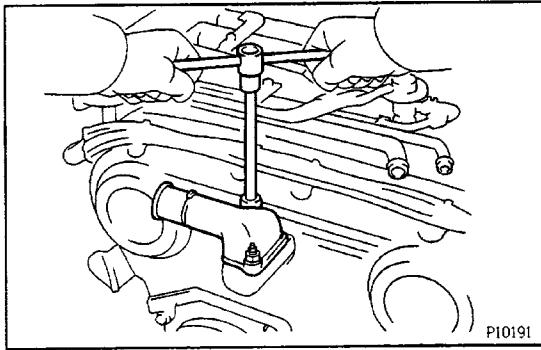
**13. REMOVE WATER OUTLET**

Remove the two nuts and water outlet.

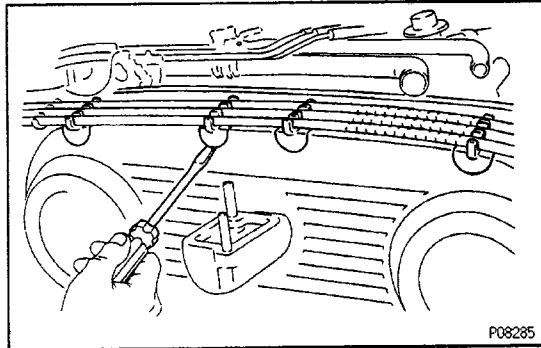
**14. REMOVE NO.2 TIMING BELT COVER**

(a) Using a screwdriver, disconnect the four high-tension cord clamps from the mounting bolts of the No.2 timing belt cover.

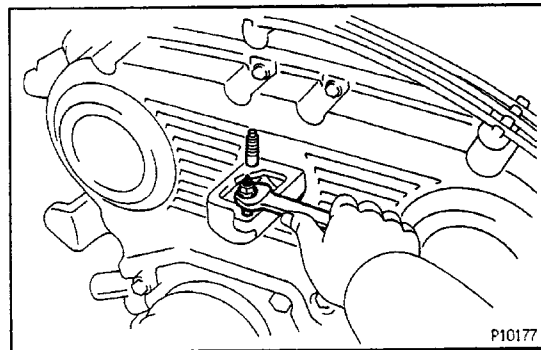

(b) Using the two water inlet nuts, remove the two stud bolts.

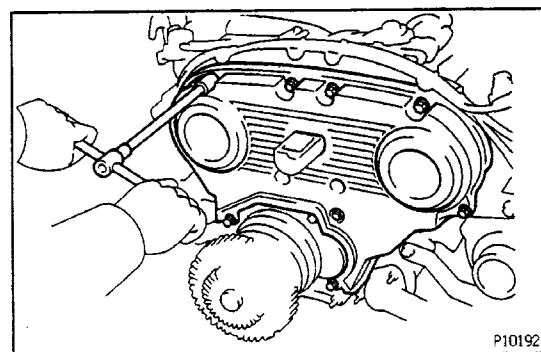

(c) Remove the eleven bolts, timing belt cover and three gaskets.

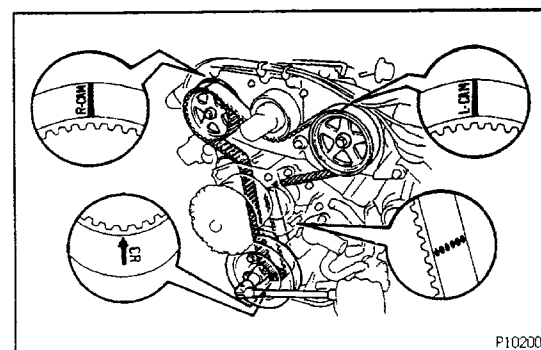
**15. IF RE-USING TIMING BELT, CHECK INSTALLATION MARKS ON TIMING BELT**

Check that there are four installation marks on the timing belt by turning the crankshaft pulley as shown in the illustration.

HINT: If the installation marks have disappeared, place a new installation mark on the timing belt before removing each part.

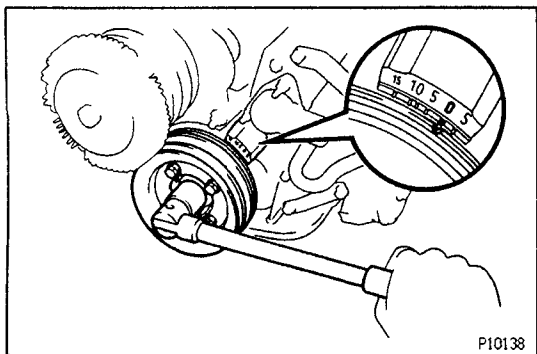
**16. SET NO.1 CYLINDER AT TDC/COMPRESSION**

- (a) Turn the crankshaft pulley and align its groove with timing mark "0" of the No.1 timing belt cover.

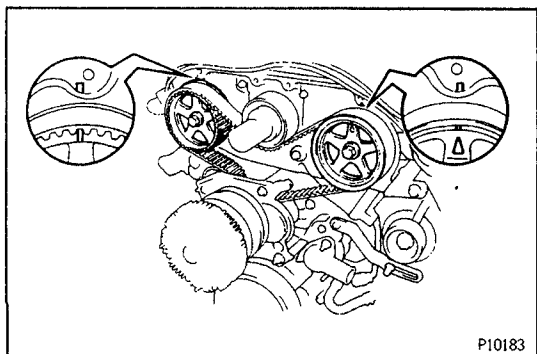

- (b) Check that the timing marks of the camshaft timing pulleys and No.3 timing belt cover are aligned. If not, turn the crankshaft pulley one revolution (360°).

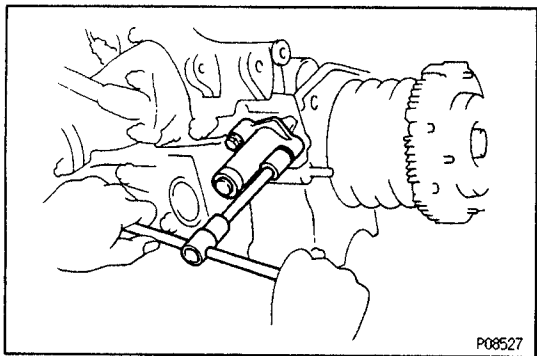
**17. REMOVE TIMING BELT TENSIONER**

Alternately loosen the two bolts, and remove them, the belt tensioner- and dust boot.

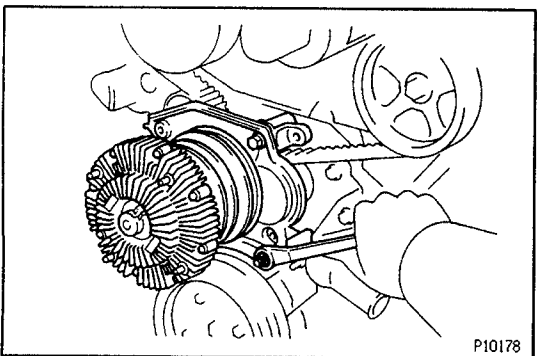
**18. REMOVE FAN BRACKET**

Remove the two bolts, nut, fan bracket and gasket.

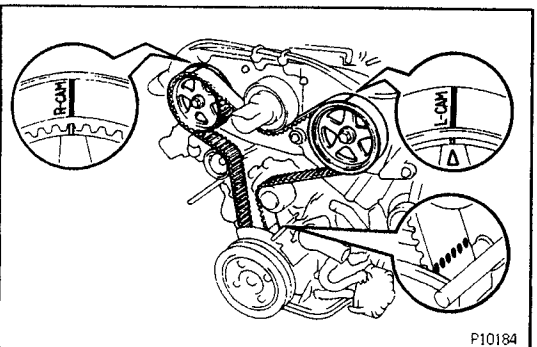
**19. DISCONNECT TIMING BELT FROM CAMSHAFT TIMING PULLEYS**

HINT (When re-using timing belt): If the installation marks have disappeared, before disconnect the timing belt from the camshaft timing pulleys, place new installation marks on the timing belt to match the timing marks of the camshaft timing pulleys, and place a new installation mark on the timing belt to match the end of the No. 1 timing belt cover.

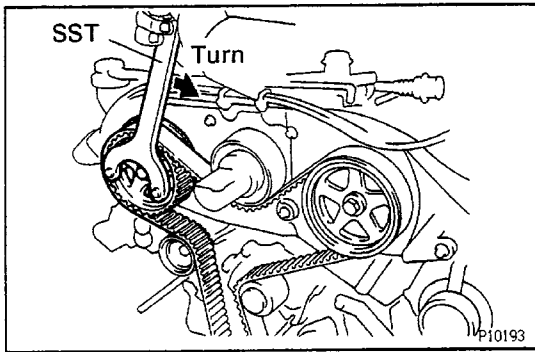

- (a) Using SST, loosen the tension spring between the LH and RH camshaft timing pulleys by slightly turning the LH camshaft timing pulley clockwise.

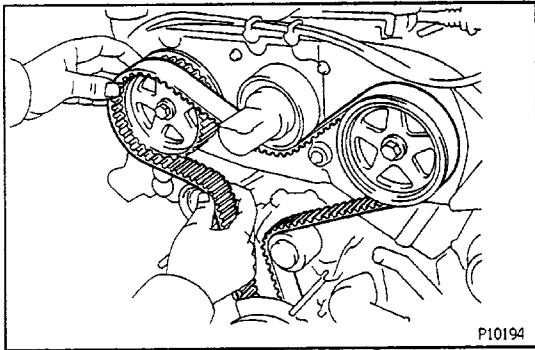

- (b) Disconnect the timing belt from the camshaft timing pulleys.

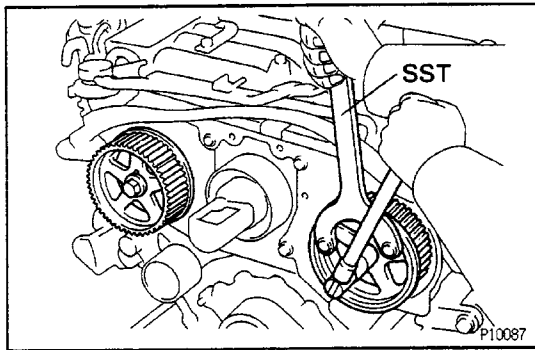

20. REMOVE CAMSHAFT TIMING PULLEYS

Using SST, remove the pulley bolt, timing pulley and knock pin. Remove the two timing pulleys.
SST 09278-54012

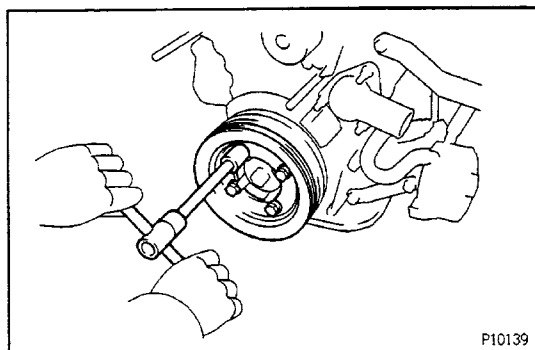

21. REMOVE CRANKSHAFT PULLEY

- (a) Remove the four bolts and PS drive belt pulley.

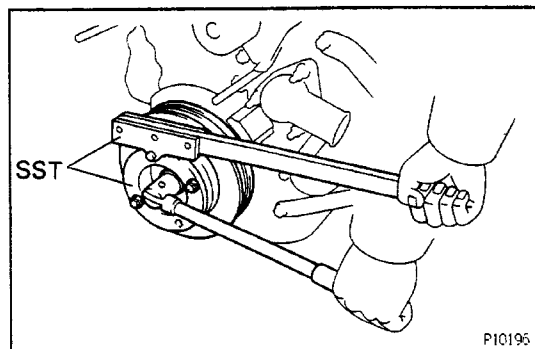

- (b) Using SST, loosen the pulley bolt.
SST 09213-58012 (90201-08131, 91111-50845),
09330-00021
(c) Remove the SST and pulley bolt.

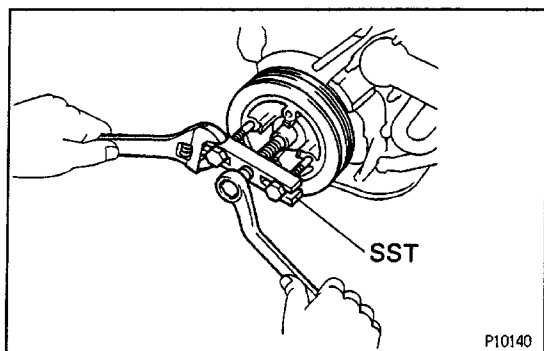

- (d) Using SST, remove the pulley.
SST 09213-31021

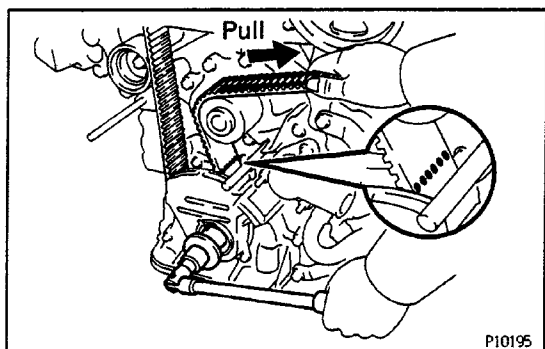

22. REMOVE NO.1 TIMING BELT COVER

HINT (When re-using timing belt): Before removing the timing belt cover, using the crankshaft pulley bolt, turn the crankshaft and align the installation mark of the timing belt with the end of the timing belt cover.

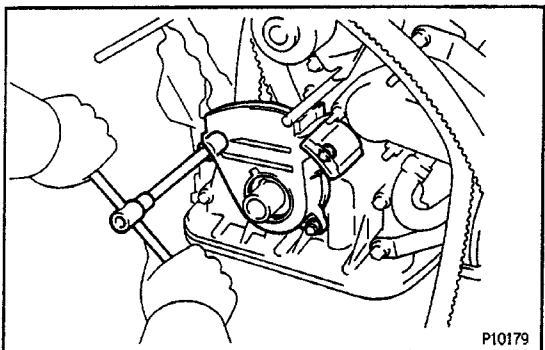

Remove the three bolts, timing belt cover and gasket.

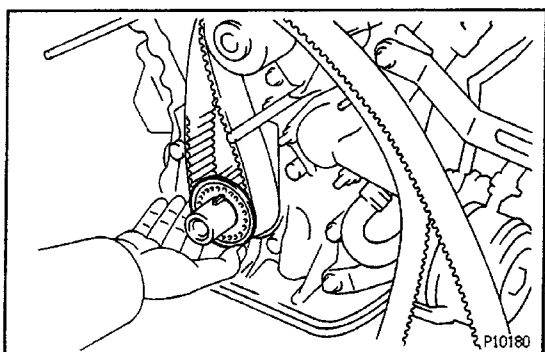

23. REMOVE TIMING BELT GUIDE

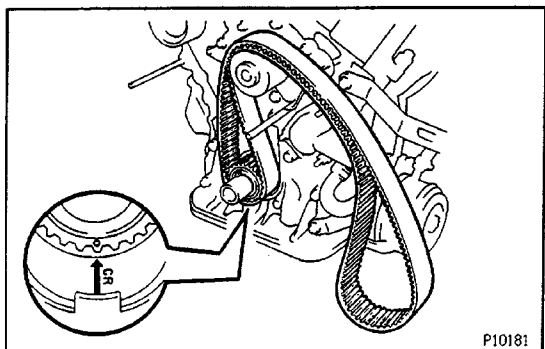

24. REMOVE TIMING BELT

HINT (When re-using timing belt): If the installation marks have disappeared, place a new installation mark on the timing belt to match the dot mark of the crankshaft timing pulley.

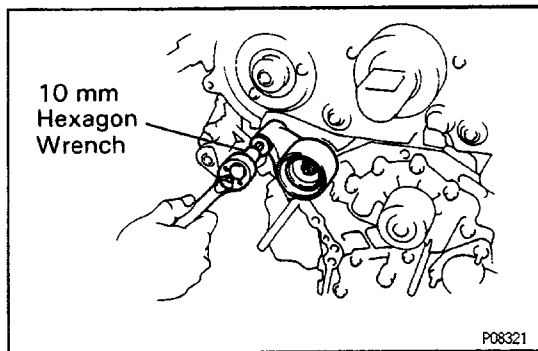
**25. REMOVE No.1 IDLER PULLEY**

Using a 10 mm hexagon wrench, remove the pivot bolt, idler pulley and plate washer.

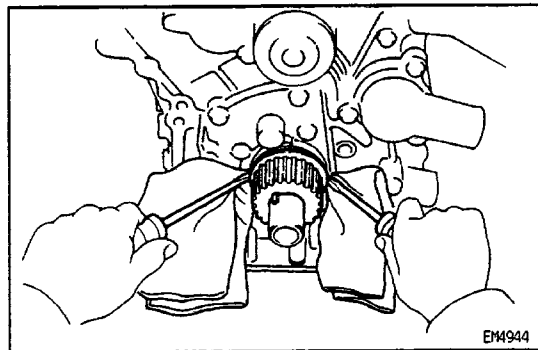
**26. REMOVE CRANKSHAFT TIMING PULLEY**

If the timing pulley cannot be removed by hand, use two screwdrivers.

HINT: Position shop rags as shown to prevent damage.

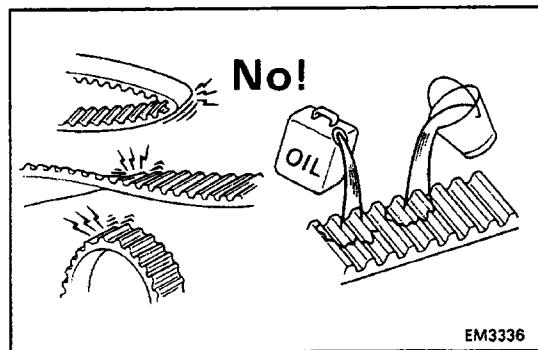
**TIMING BELT COMPONENTS INSPECTION****1. INSPECT TIMING BELT****NOTICE:**

- Do not bend, twist or turn the timing belt inside out. Do not allow the timing belt to come into contact with oil, water or steam.
- Do not utilize timing belt tension when installing or removing the mounting bolt of the camshaft timing pulley.

If there are any defects as shown in the illustration, check the following points:

- (a) Premature parting
- Check the proper installation.
 - Check the timing cover gasket for damage and proper installation.

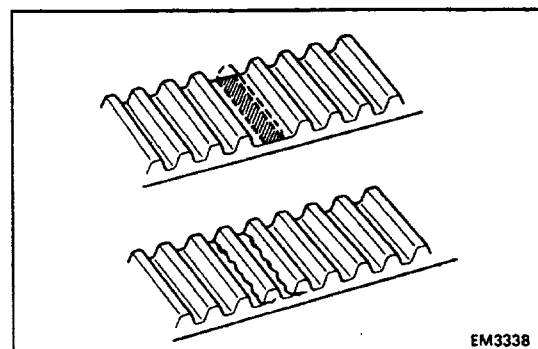
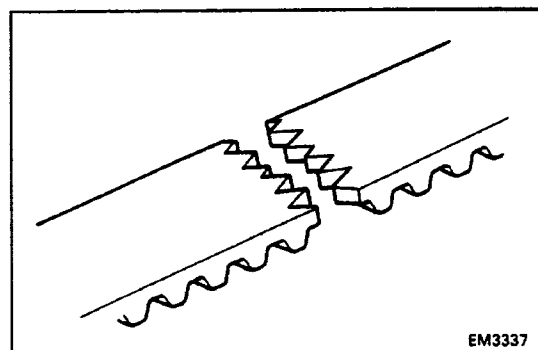

- (b) If the belt teeth are cracked or damaged, check to see if either camshaft or water pump is locked.

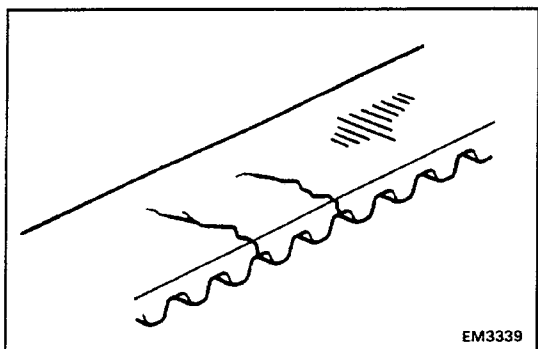

- (c) If there is noticeable wear or cracks on the belt face; check to see if there are nicks on the side of the idle pulley lock.

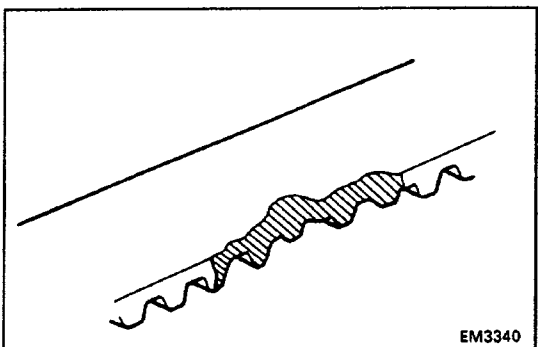

- (d) If there is wear or damage on only one side of the belt, check the belt guide and the alignment of each pulley.

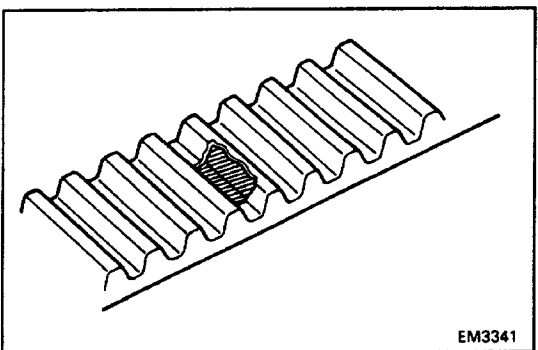

- (e) If there is noticeable wear on the belt teeth, check the timing cover for damage, correct gasket installation, and foreign material on the pulley teeth. If necessary, replace the timing belt.

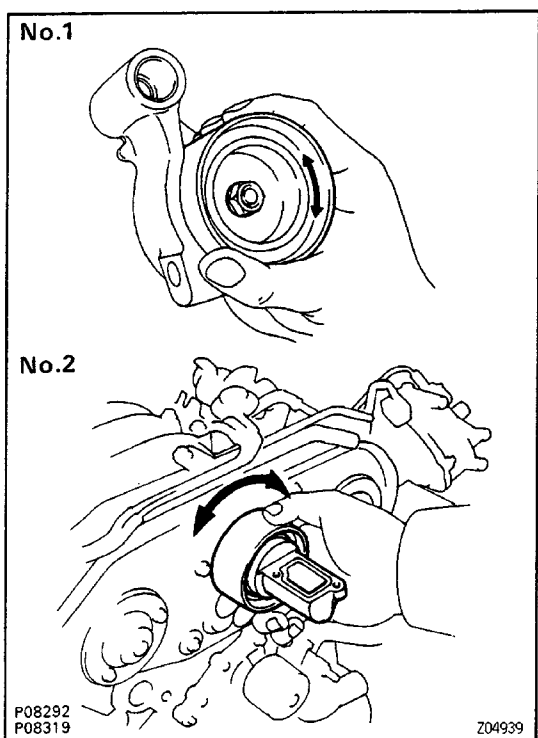

2. INSPECT IDLER PULLEYS

Check that the idler pulley turns smoothly.
If necessary, replace the idler pulley.

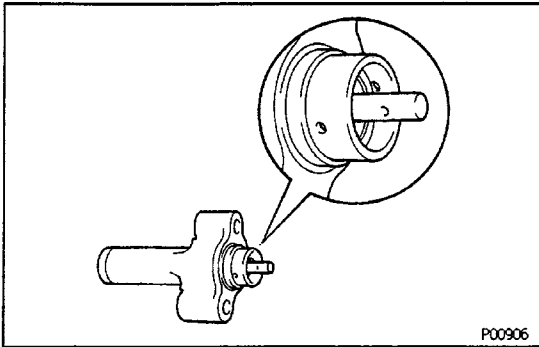

3. INSPECT TIMING BELT TENSIONER

(a) Visually check tensioner for oil leakage.

HINT: If there is only the faintest trace of oil on the seal on the push rod side, the tensioner is all right. If leakage is found, replace the tensioner.

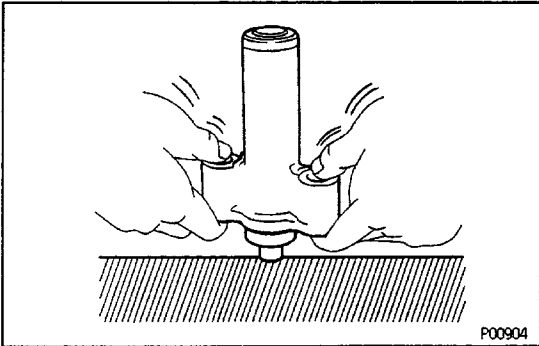

(b) Hold the tensioner with both hands, and push the push rod firmly against the floor or wall to check that it doesn't move.

If the push rod moves, replace the tensioner.

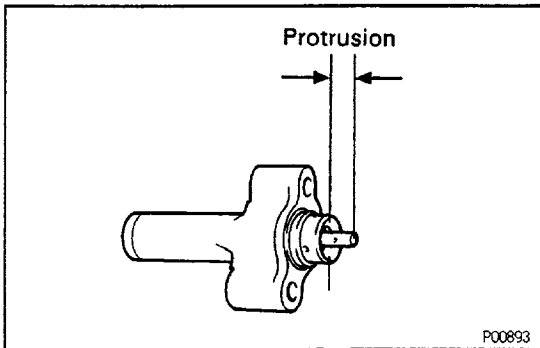

(c) Measure the protrusion of the push rod from the housing end.

Protrusion:

10.0 – 10.5 mm (0.394 – 0.413 in.)

If the protrusion is not as specified, replace the tensioner.

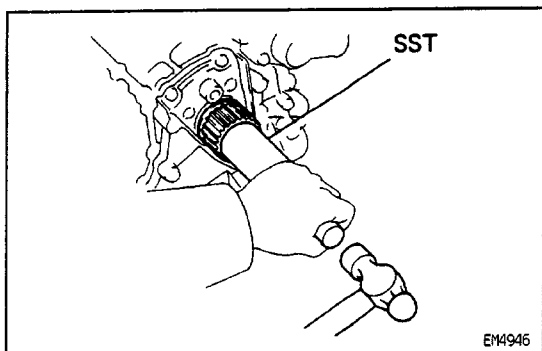

TIMING BELT INSTALLATION

(See Components)

1. INSTALL CRANKSHAFT TIMING PULLEY

- (a) Align the timing pulley set key with the key groove of the pulley.
- (b) Using SST and a hammer, tap in the timing pulley, facing the flange side inward.
SST 09214-60010

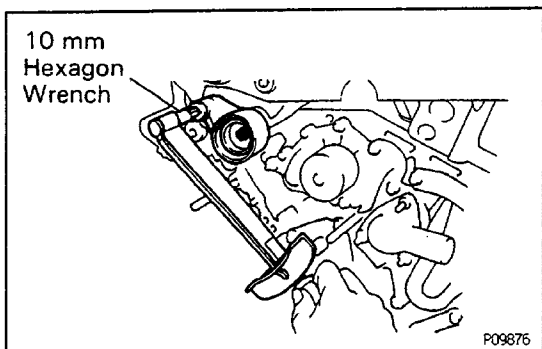

2. INSTALL NO.1 IDLER PULLEY

- (a) Using a 10 mm hexagon wrench, install the plate washer and idler pulley with the pivot bolt.

Torque: 34 N-m (350 kgf-cm, 25 ft-lbf)

- (b) Check that the pulley bracket moves smoothly.

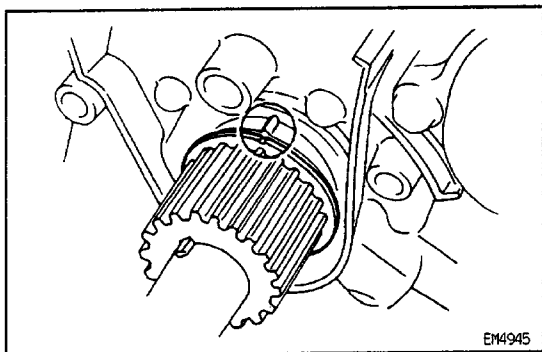

3. TEMPORARILY INSTALL TIMING BELT

NOTICE: The engine should be cold.

- (a) Using the crankshaft pulley bolt, turn the crankshaft and align the timing marks of the crankshaft timing pulley and oil pump body.

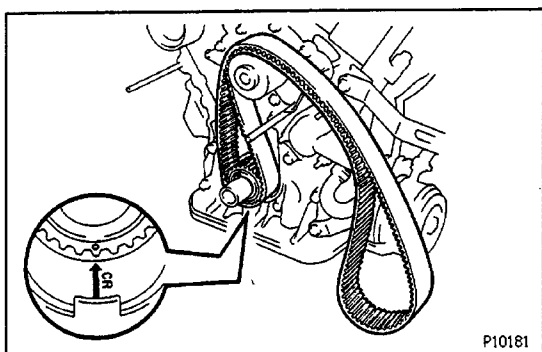

- (b) Remove any oil or water on the crankshaft timing pulley and water pump pulley, and keep them clean.
- (c) Align the installation mark on the timing belt with the dot mark of the crankshaft timing pulley.
- (d) Install the timing belt on the crankshaft timing pulley and water pump pulley.

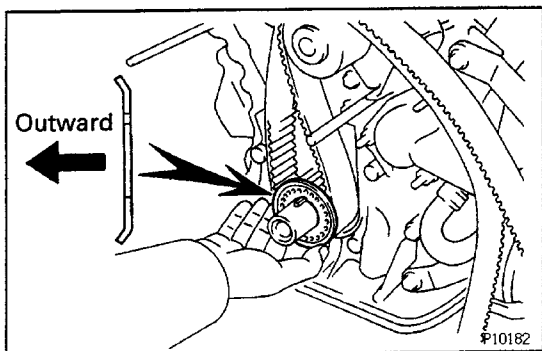

4. INSTALL TIMING BELT GUIDE

Install the belt guide, facing the cup side outward.

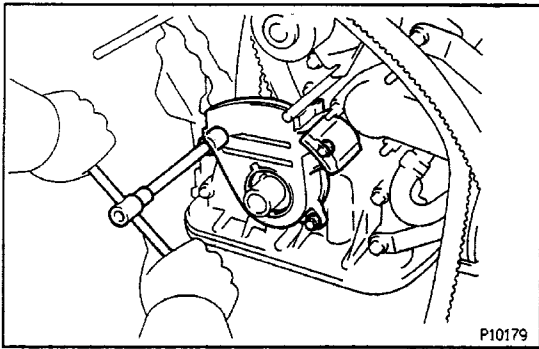

5. INSTALL NO.1 TIMING BELT COVER

- (a) Install the gasket to the timing belt cover.
- (b) Install the timing belt cover with the three bolts.

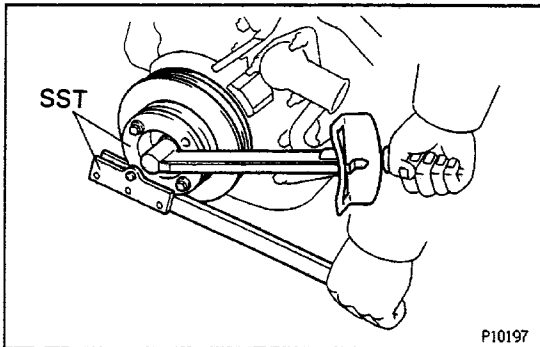

6. INSTALL CRANKSHAFT PULLEY

- (a) Align the pulley set key with the key groove of the crankshaft pulley.
- (b) Temporarily install the pulley bolt.
- (c) Using SST, tighten the pulley bolt.
SST 09213-58012 (90201 -08131, 91111 -50845),
09330-00021
Torque: 245 N-m (2,500 kgf-cm, 181 ft-lbf)

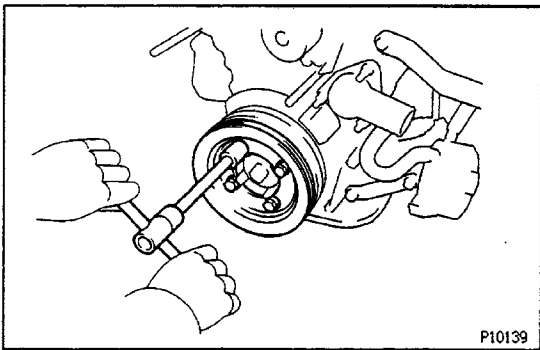

- (d) Install the PS drive belt pulley with the four bolts.

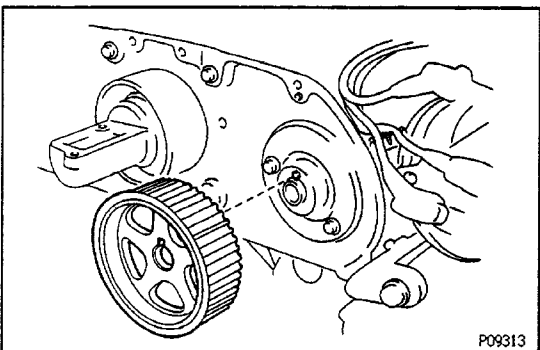

7. INSTALL LH CAMSHAFT TIMING PULLEY

- (a) Install the knock pin to the camshaft.
- (b) Align the knock pin hole of the camshaft with the knock pin groove of the timing pulley.
- (c) Slide the timing pulley on the camshaft, facing the flange side outward.

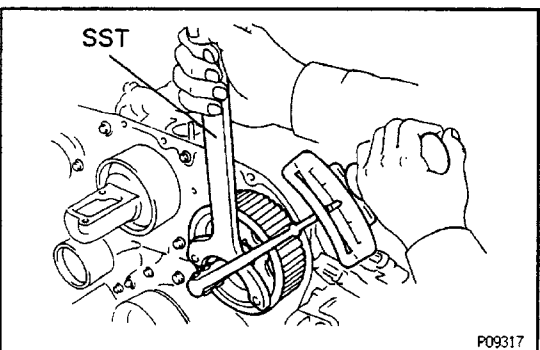

- (d) Using SST, install the pulley bolt.

SST 09278-54012

Torque: 108 N-m (1,100 kgf-cm, 80 ft-lbf)

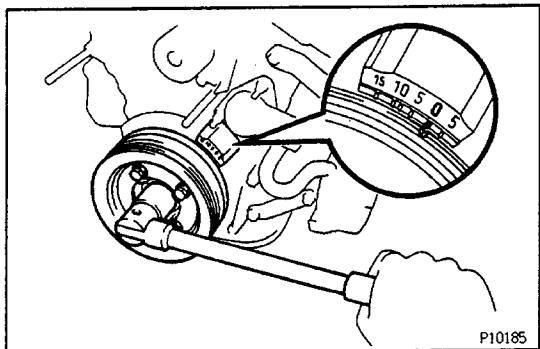

8. SET NO.1 CYLINDER TO TDC/COMPRESSION

(a) (Crankshaft Position)

Turn the crankshaft pulley, and align its groove with timing mark "0" of the No.1 timing belt cover.

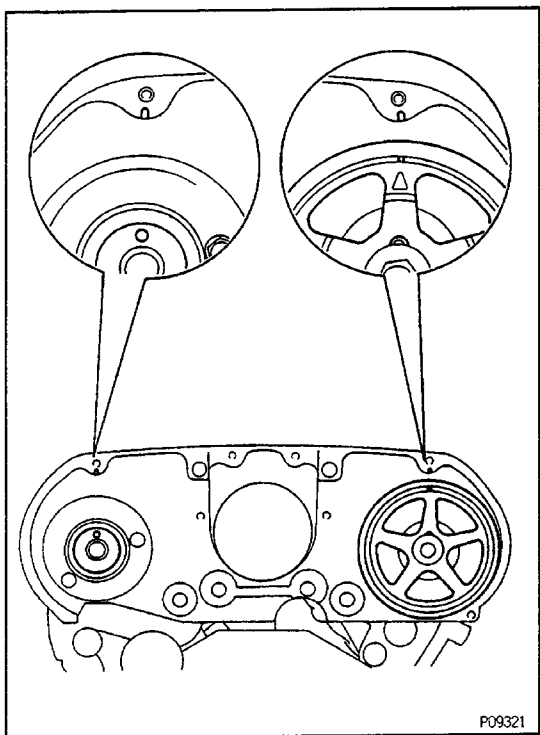

(b) (RH Camshaft Pulley Position)

Turn the camshaft, align the knock pin hole of the camshaft with the timing mark of the No.3 timing belt cover.

(c) (LH Camshaft Pulley Position)

Turn the camshaft timing pulley, align the timing marks of the camshaft timing pulley and No.3 timing belt cover.

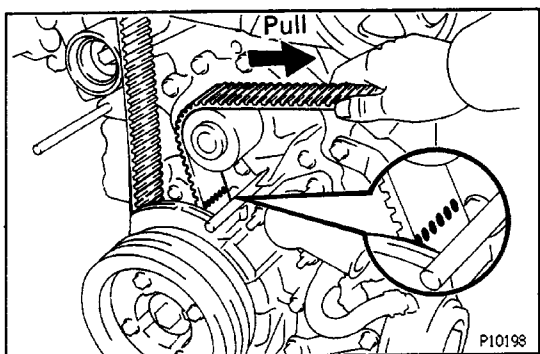

9. CONNECT TIMING BELT TO LH CAMSHAFT TIMING PULLEY

(a) Check that the installation mark on the timing belt is aligned with the end of the No.1 timing belt cover.

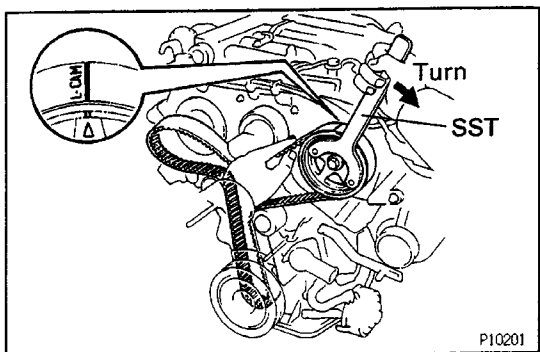

(b) Remove any oil or water on the LH camshaft timing pulley, and keep it clean.

(c) Using SST, slightly turn the LH camshaft timing pulley clockwise. Align the installation mark on the timing belt with the timing mark of the camshaft timing pulley, and hang the timing belt on the LH camshaft timing pulley.

SST 09278-54012

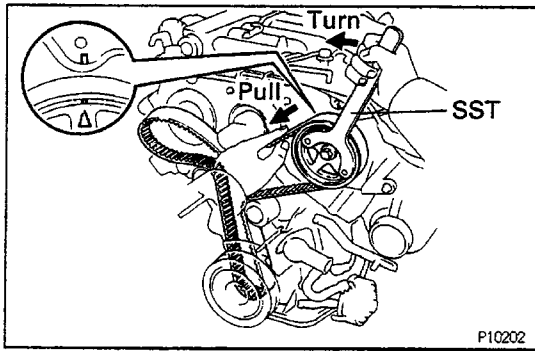

- (d) Using SST, align the timing marks of the LH camshaft pulley and No.3 timing belt cover.
SST 09278-54012
- (e) Check that the timing belt has tension between the crankshaft timing pulley and LH camshaft timing pulley.

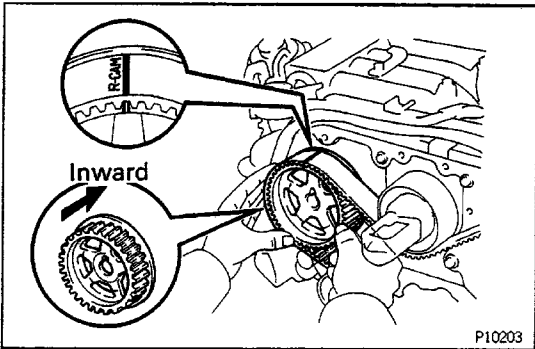

10. INSTALL RH CAMSHAFT TIMING PULLEY AND TIMING BELT

- (a) Remove any oil or water on the RH camshaft timing pulley, No. 1 idler pulley and No.2 idler pulley, and keep them clean.
- (b) Align the installation mark on the timing belt with the timing mark of the RH camshaft timing pulley, and hang the timing belt on the RH camshaft timing pulley, facing the flange side inward.

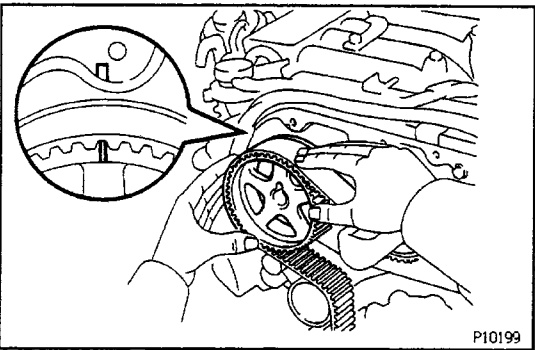

- (c) Slide the RH camshaft timing pulley on the camshaft.
- (d) Align the timing marks of the RH camshaft timing pulley and No.3 timing belt cover.

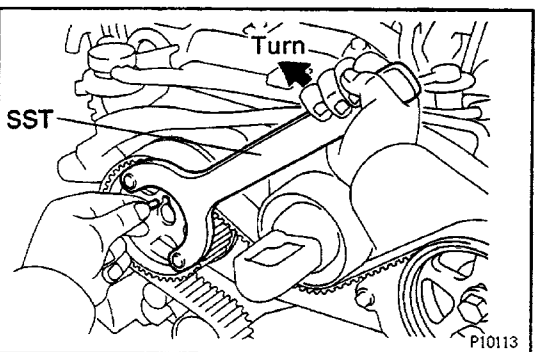

- (e) Using SST, align the knock pin hole of the camshaft with the knock pin groove of the pulley and install the knock pin.
SST 08278-54012

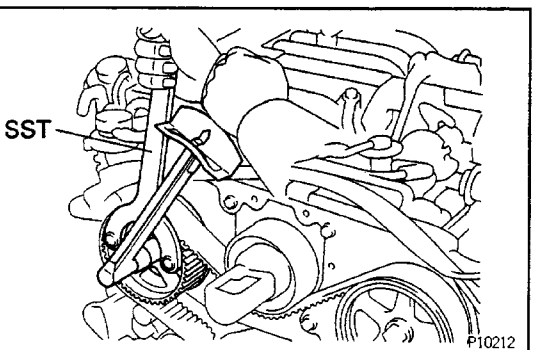

- (f) Using SST, install the pulley bolt.
SST 09278-54012

Torque: 108 N-m (1,100 kgf-cm, 80 ft-lbf)

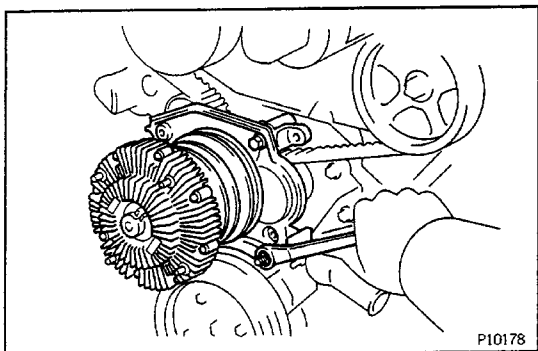

11. INSTALL FAN BRACKET

- (a) Install the gasket to the fan pulley bracket.
- (b) Install the fan bracket with the two bolts and nut.
Torque: 41 N-m (420 kgf-cm, 30 ft-lbf)

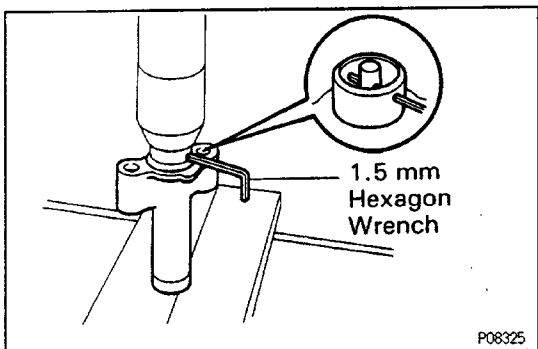

12. SET TIMING BELT TENSIONER

- (a) Using a press, slowly press in the push rod using 981 – 9,807 N (100 – 1,000 kgf, 200 – 2,205 lbf) of force.
- (b) Align the holes of the push rod and housing, pass a 1.5 mm hexagon wrench through the holes to keep the setting position of the push rod.
- (c) Release the press.

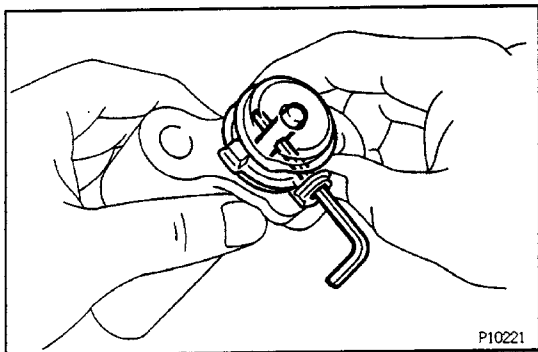

- (d) Install the dust boot to the tensioner.

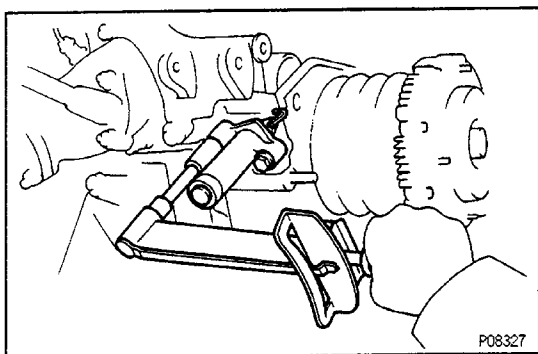

13. INSTALL TIMING BELT TENSIONER

- (a) Temporarily install the belt tensioner with the two bolts.
- (b) Alternately tighten the two bolts.
Torque: 26 N-m (270 kgf-cm, 20 ft-lbf)

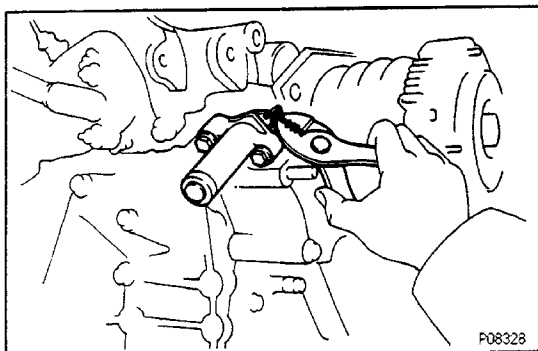

- (c) Using pliers, remove the 1.5 mm hexagon wrench from the belt tensioner.

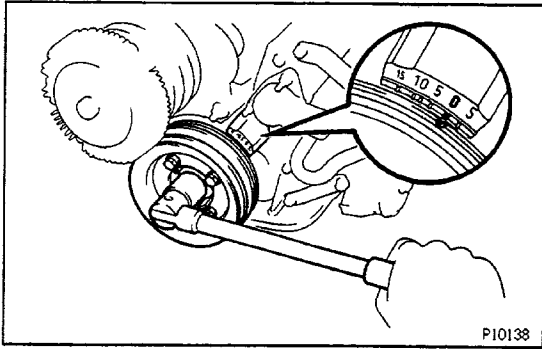

14. CHECK VALVE TIMING

- (a) Slowly turn the crankshaft pulley two revolutions from TDC to TDC.

NOTICE: Always turn the crankshaft pulley clockwise.

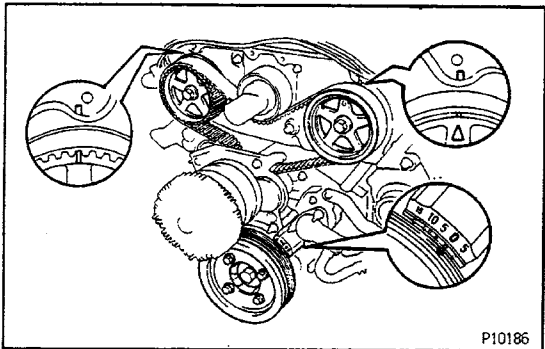

- (b) Check that each pulley aligns with the timing marks as shown in the illustration.

If the timing marks do not align, remove the timing belt and reinstall it.

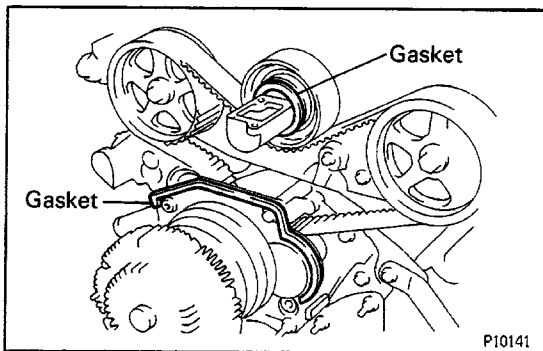

15. INSTALL NO.2 TIMING BELT COVER

- (a) Install the gasket to the No.2 idler pulley.

- (b) Install the gasket to the fan bracket.

- (c) Install the gasket to the timing belt cover.

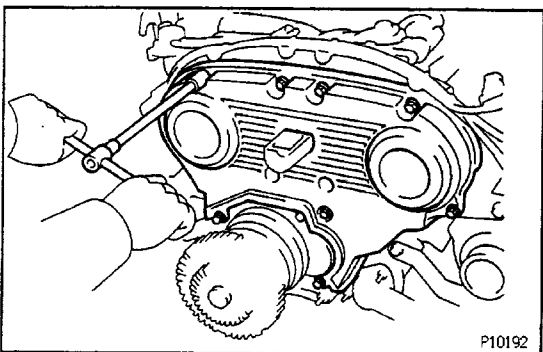

- (d) Install the timing belt cover with the eleven bolts.

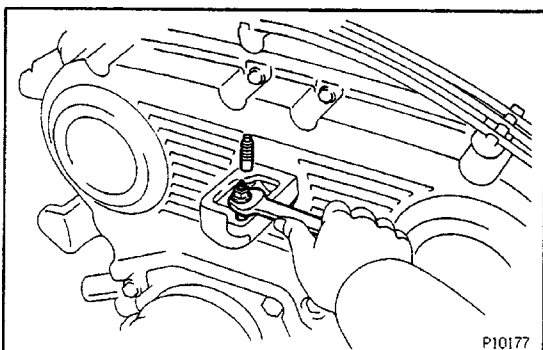

- (e) Using the two water outlet nuts, install the two stud bolts.

- (f) Connect the four clamps on the high-tension cords to the mounting bolts of the No.2 timing belt cover.

16. INSTALL WATER OUTLET

(a) Remove any old packing (FIPG) material and be careful not to drop any oil on the contact surfaces of the water outlet and the water outlet housing on the No.2 idler pulley.

- Using a razor blade and gasket scraper, remove all the old packing (FIPG) material from the gasket surfaces and sealing groove.
- Thoroughly clean all components to remove all the loose material.
- Using a non-residue solvent, clean both sealing surfaces.

(b) Apply seal packing to the sealing groove of the water outlet as shown in the illustration.

Seat packing:**Part No. 08826-00100 or equivalent**

- Install a nozzle that has been cut to a 2 – 3 mm (0.08 – 0.12 in.) opening.
- Parts must be assembled within 5 minutes of application. Otherwise the material must be removed and reapplied.
- Immediately remove nozzle from the tube and reinstall cap.

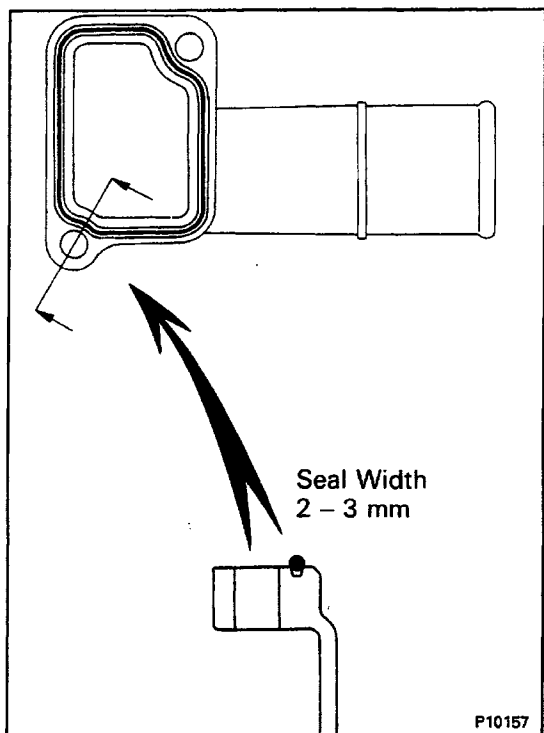

(c) Install the water outlet with the two bolts. Alternately tighten the bolts.

Torque: 8.3 N-m (85 kgf-cm, 73 in.-lbf)

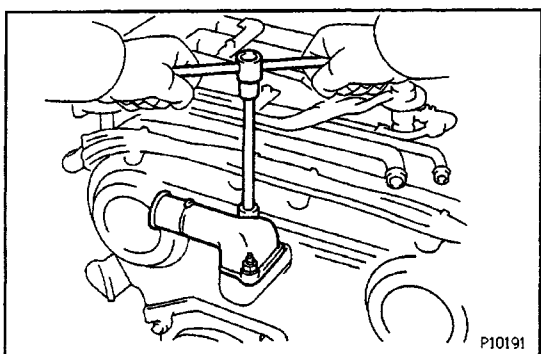
17. INSTALL GENERATOR DRIVE BELT**18. INSTALL COOLING FAN**

Install the cooling fan with the four nuts.

Torque: 5.4 N-m (55 kgf-cm, 48in.-lbf)

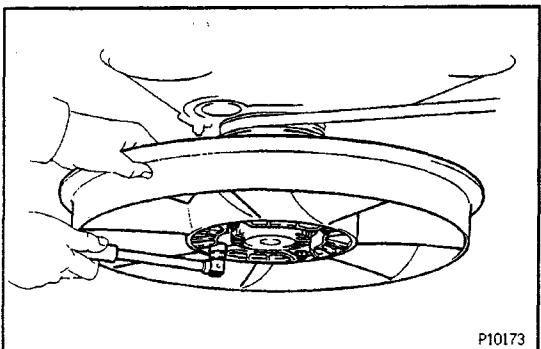
19. INSTALL A/C DRIVE BELT

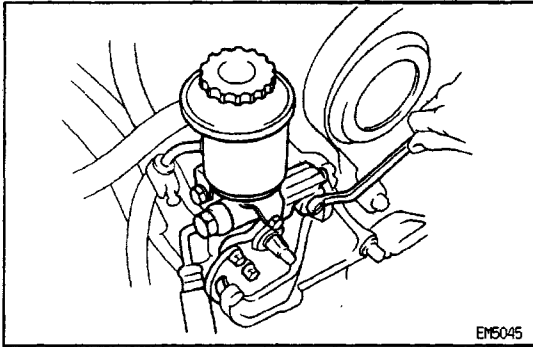
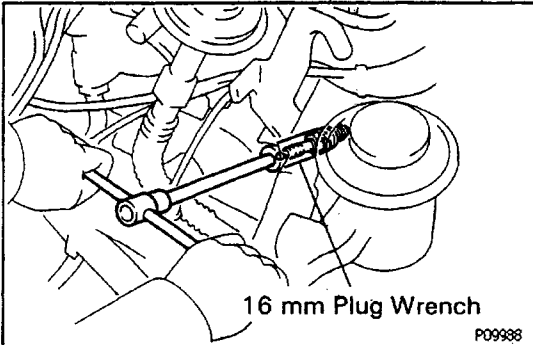
**20. INSTALL PS PUMP****21. INSTALL PS PUMP PULLEY AND DRIVE BELT****22. INSTALL SPARK PLUGS**

Using a 16 mm plug wrench, install the six spark plugs.

Torque: 18 N-m (180 kgf-cm, 13 ft-lbf)

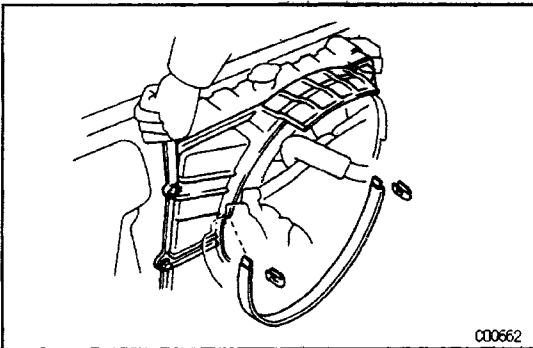
23. CONNECT HIGH-TENSION CORDS TO SPARK PLUGS**24. CONNECT NO.2 AND NO.3 AIR HOSES TO AIR PIPE****25. INSTALL RADIATOR**

- (a) Install the radiator with the four bolts.
- (b) Install the No.1 fan shroud with the four bolts.
- (c) Install the No.2 fan shroud with the two clips.

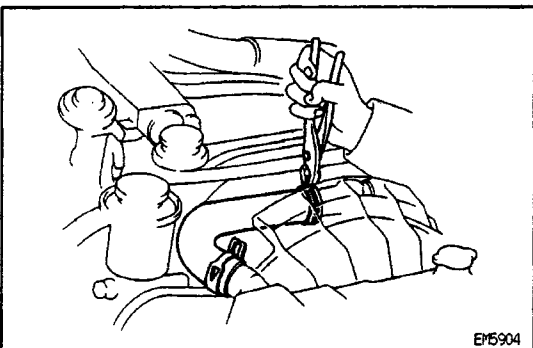

- (d) Install the radiator hoses.
- (e) (A/T only)
Connect the oil cooler hoses.
- (f) Connect the reservoir tank hose.

26. CONNECT CABLE TO NEGATIVE TERMINAL OF BATTERY**27. FILL WITH ENGINE COOLANT****28. START ENGINE AND CHECK FOR LEAKS****29. RECHECK ENGINE COOLANT LEVEL**