

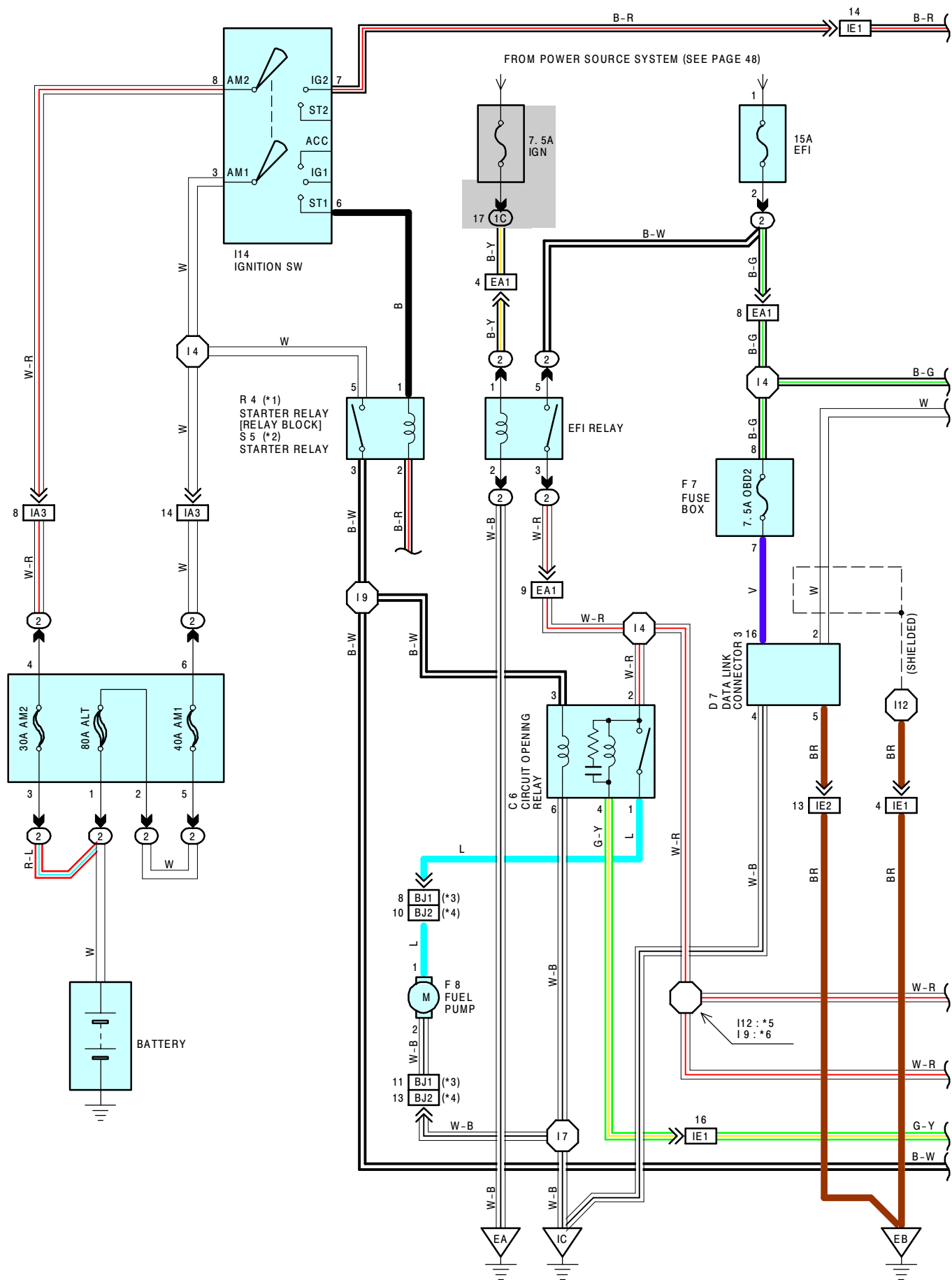

ENGINE CONTROL (5VZ-FE M/T)

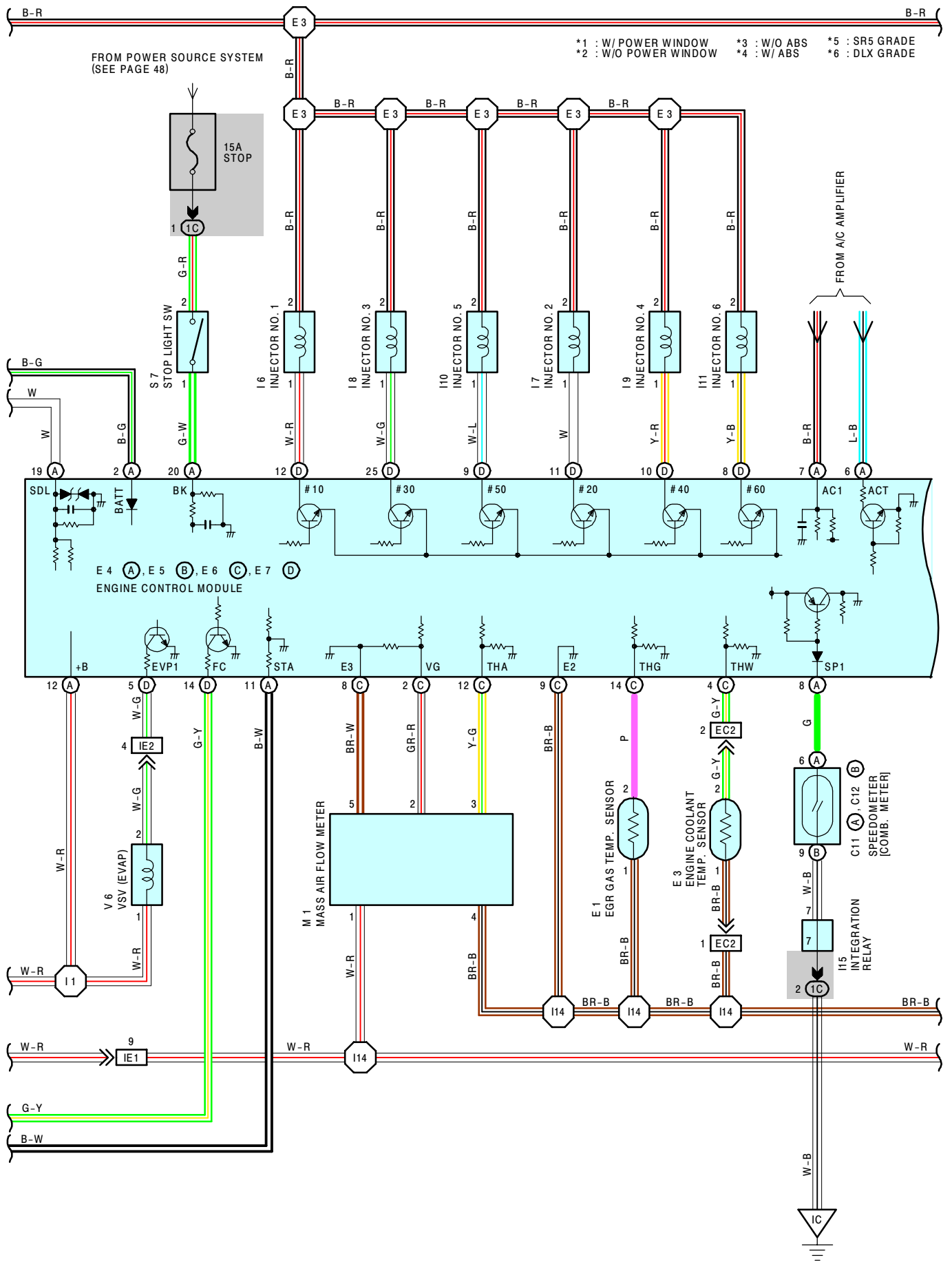





ENGINE CONTROL (5VZ-FE M/T)

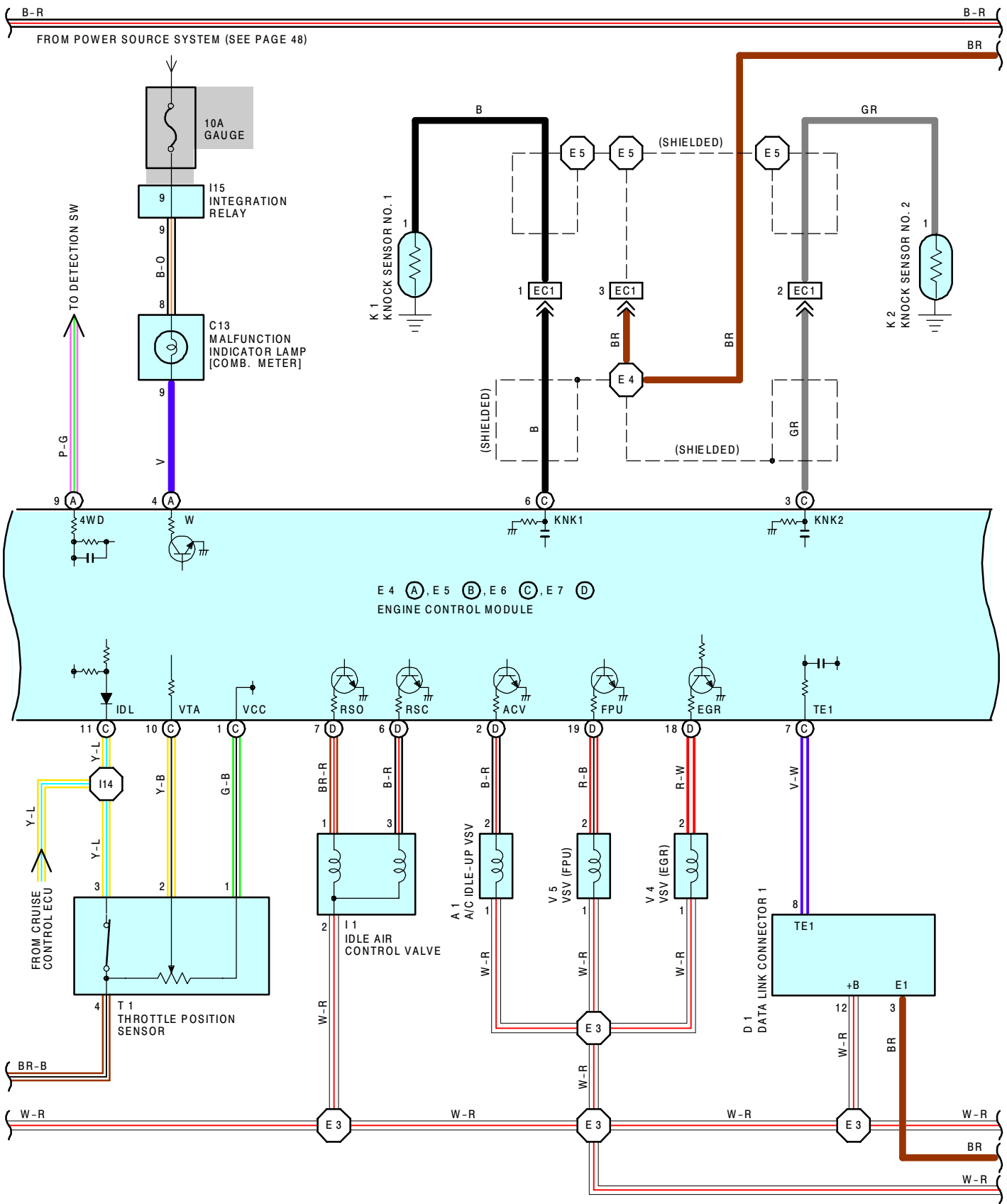

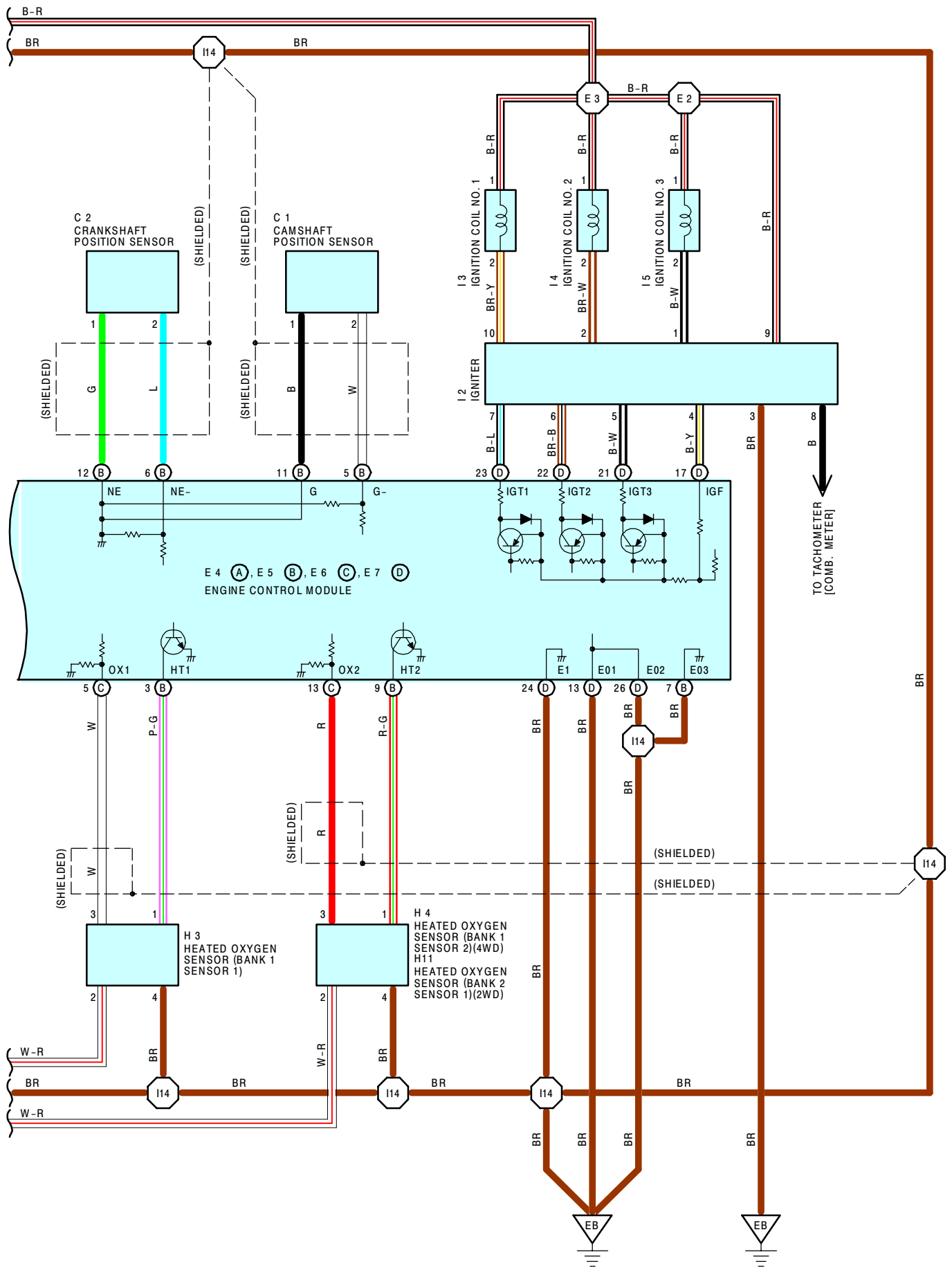



ENGINE CONTROL (5VZ-FE M/T)

SERVICE HINTS

EFI RELAY

(2) 5 - (2) 3 : CLOSED WITH IGNITION SW AT **ON** OR **ST** POSITION

C 6 CIRCUIT OPENING RELAY

1-2 : CLOSED WITH STARTER RUNNING

I 6, I 7, I 8, I 9, I 10, I 11 INJECTOR

1-2 : **13.4-14.2** Ω

T 1 THROTTLE POSITION SENSOR

3-1 : **0.2-0.8** K Ω WITH CLEARANCE BETWEEN LEVER AND STOP SCREW **0** MM (**0** IN.)

2-1 : **2.3** K Ω OR LESS WITH CLEARANCE BETWEEN LEVER AND STOP SCREW **0.50** MM (**0.0197** IN.)

INFINITY WITH CLEARANCE BETWEEN LEVER AND STOP SCREW **0.77** MM (**0.0303** IN.)

3-1 : **3.3-10** K Ω WITH THROTTLE VALVE FULLY OPEN

4-1 : **4-9** K Ω

E 3 ENGINE COOLANT TEMP. SENSOR

1-2 : **10-20** K Ω (**-20** °C, **-4** °F)

4-7 K Ω (**0** °C, **32** °F)

2-3 K Ω (**20** °C, **68** °F)

0.9-1.3 K Ω (**40** °C, **104** °F)

0.4-0.7 K Ω (**60** °C, **140** °F)

0.2-0.4 K Ω (**80** °C, **176** °F)

E 4 (A), E 5 (B), E 6 (C), E 7 (D) ENGINE CONTROL MODULE

VOLTAGE AT ECU CONNECTORS

+B -E1 : **9-14** VOLTS (IGNITION SW ON)

BATT -E1 : **9-14** VOLTS (ALWAYS)

VCC -E2 : **4.5-5.5** VOLTS (IGNITION SW ON)

IDL -E2 : **9-14** VOLTS (IGNITION SW ON AND THROTTLE VALVE OPEN)

VTA -E2 : **0.3-0.8** VOLTS (IGNITION SW ON AND THROTTLE VALVE FULLY CLOSED)

3.2-4.9 VOLTS (IGNITION SW ON AND THROTTLE VALVE FULLY OPEN)

IGT1, IGT2, IGT3-E1 : PULSE GENERATION (CRANKING OR IDLING)

STA -E1 : **6** VOLTS OR MORE (IGNITION SW AT **ST** POSITION)

#10, #20, #30, #40, #50, #60-E1 : **9-14** VOLTS (IGNITION SW ON)

W -E1 : **9-14** VOLTS (NO TROUBLE AND ENGINE RUNNING)

THA -E2 : **0.5-3.4** VOLTS (IGNITION SW ON AND INTAKE AIR TEMP. **20** °C, **68** °F)

THW -E2 : **0.2-1.0** VOLTS (IGNITION SW ON AND COOLANT TEMP. **80** °C, **176** °F)

SP1 -E1 : PULSE GENERATION WITH VEHICLE MOVING

BK -E1 : **7.5-14** VOLTS (STOP LIGHT SW ON)

RESISTANCE AT ECU WIRING CONNECTOR

(DISCONNECT WIRING CONNECTOR)

IDL -E2 : INFINITY (THROTTLE VALVE OPEN)

0-100 Ω (THROTTLE VALVE FULLY CLOSED)

VTA -E2 : **3.3-10** K Ω (THROTTLE VALVE FULLY OPEN)

0.2-0.8 K Ω (THROTTLE VALVE FULLY CLOSED)

THA -E2 : **2-3** K Ω (INTAKE AIR TEMP. **20** °C, **68** °F)

THW -E2 : **0.2-0.4** K Ω (COOLANT TEMP. **80** °C, **178** °F)

+B -E2 : **0.2-0.4** K Ω

NE -E1 : **140-180** Ω

 : PARTS LOCATION

CODE	SEE PAGE	CODE	SEE PAGE	CODE	SEE PAGE
A 1	22	F 7	27	I11	23
C 1	22	F 8	28	I14	27
C 2	22	H 3	22	I15	27
C 6	26	H 4	22	K 1	23
C11	A 26	H11	22	K 2	23
C12	B 26	I 1	23	M 1	23
C13	26	I 2	23	R 4	27
D 1	22	I 3	23	S 5	27
D 7	26	I 4	23	S 7	27
E 1	22	I 5	23	T 1	23
E 3	22	I 6	23	V 4	23
E 4	A 27	I 7	23	V 5	23
E 5	B 27	I 8	23	V 6	23
E 6	C 27	I 9	23		
E 7	D 27	I10	23		

 : RELAY BLOCKS

CODE	SEE PAGE	RELAY BLOCKS (RELAY BLOCK LOCATION)
2	19	R/B NO. 2 (ENGINE COMPARTMENT LEFT)

 : JUNCTION BLOCK AND WIRE HARNESS CONNECTOR

CODE	SEE PAGE	JUNCTION BLOCK AND WIRE HARNESS (CONNECTOR LOCATION)
1C	20	COWL WIRE AND J/B NO. 1 (LEFT KICK PANEL)

 : CONNECTOR JOINING WIRE HARNESS AND WIRE HARNESS

CODE	SEE PAGE	JOINING WIRE HARNESS AND WIRE HARNESS (CONNECTOR LOCATION)
EA1	30	COWL WIRE AND ENGINE ROOM MAIN WIRE (INNER THE R/B NO. 2)
EC1	30	SENSOR WIRE AND ENGINE WIRE (OVER THE CYLINDER HEAD)
EC2	30	ENGINE WIRE AND SENSOR WIRE (OVER THE CYLINDER HEAD)
IA3	34	ENGINE ROOM MAIN WIRE AND COWL WIRE (LEFT KICK PANEL)
IE1	34	ENGINE WIRE AND COWL WIRE (RIGHT KICK PANEL)
IE2		
BJ1	36	FRAME WIRE AND COWL WIRE (UNDER THE PASSENGER'S SEAT)
BJ2		

 : GROUND POINTS

CODE	SEE PAGE	GROUND POINTS LOCATION
EA	32	FRONT LEFT FENDER
EB	32	NEAR THE THROTTLE BODY
IC	34	LEFT KICK PANEL

 : SPLICE POINTS

CODE	SEE PAGE	WIRE HARNESS WITH SPLICE POINTS	CODE	SEE PAGE	WIRE HARNESS WITH SPLICE POINTS
E 2	30	ENGINE WIRE	I 4	34	COWL WIRE
E 3			I 7		
E 4			I 9		
E 5	30	SENSOR WIRE	I12	34	ENGINE WIRE
I 1	34	COWL WIRE	I14		



ENGINE CONTROL (5VZ-FE M/T)

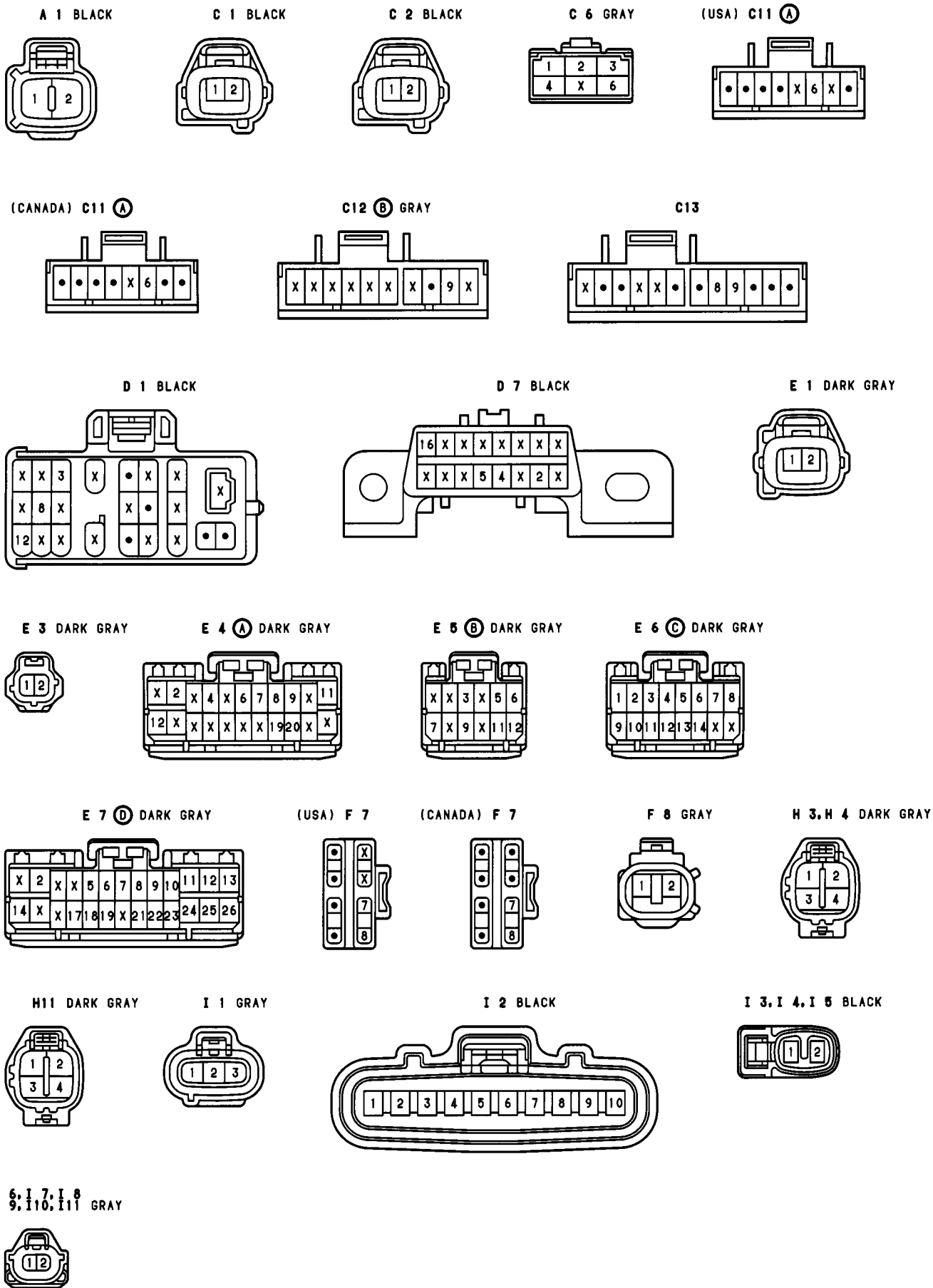

*1: W/ POWER WINDOW
*2: W/O POWER WINDOW

I14 BLACK

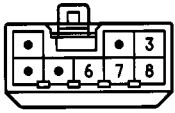

(SR5 GRADE) I15

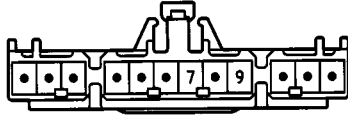

(DLX GRADE) I15

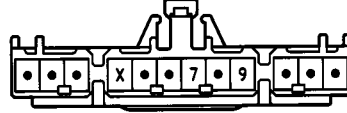

K 1, K 2 DARK GRAY



M 1 BLACK

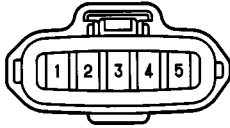

(*1) R 4

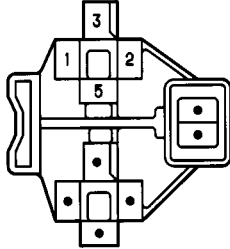

(*2) S 5

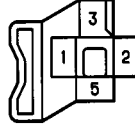

(W/ CRUISE CONTROL) S 7

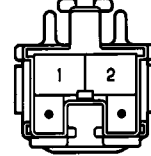

(W/O CRUISE CONTROL) S 7 BLACK

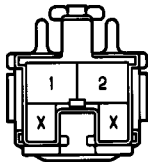

T 1 BLACK



V 4 GREEN



V 5 BROWN

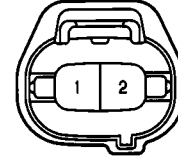

V 6 BLACK

