

Typical Install Instructions



Read & understand all steps of these instructions before beginning this installation.

Kit is for off-road use, not for use on the highways, or in California.

REDLINE WEBER Kit K610

Chrysler / Mitsubishi with Manual Transmission

Using REDLINE Weber 32/36 DGEV

These instructions are intended as a general guide for installation.
Certain steps may vary slightly for different vehicles.

Jetting Specifications

Jetting specifications of carburetors supplied in kits may vary slightly
and will always be correct for the intended application.

Tools Needed

Combination, box or open-end wrenches
Socket set
Screwdrivers (regular and Phillips)
Pliers
6mm allen wrench
Gasket scraper, Knife
Wiping rags, Cleaning solvent
Gasket sealer

Parts Supplied with Installation Kit

Weber 32/36 DGEV
Carburetor adapter
Hardware kit
Linkage kit
Chrome air filter

TUNE – UP SPECIFICATIONS

All engine tune-up specifications for the REDLINE Weber Carburetor remains the same as those specified by the factory for the original unit. A suitable qualified dealer or independent garage, using infrared gas analyzing equipment, should carry out emission tune-up.

NOTE: Late model vehicles fitted with Emission Control Systems have many vacuum lines and electrical connections in their fuel systems. It is essential when dismantling, that disconnected lines be identified with a number tag or label system. Establish function of any device reconnected or disconnected.

RECOMMENDED ADDITIONAL PARTS

1. It is recommended to obtain a new fuel filter and install it when installing this kit.
2. Many late model vehicles use a high-pressure fuel system. For aggressive driving or off road use, we recommend a pressure regulator adjusted to 2.5 lbs. for more stable fuel and float control.

Universal Disassembly



1. Disconnect battery.
2. Remove the gas cap.
3. Drain some water from the cooling system, (enough so the water level in the engine is below the intake system.) CAUTION: Hot water may be under pressure and dangerous.
4. Remove factory air filter assembly and all attaching hardware and hoses. Use a tag and numbering system to identify hoses for reinstallation.
5. Remove factory vacuum lines from carburetor. These will not be reused with the exception of the power brake take off.
6. When disconnecting the various vacuum and electrical devices it is recommended that they be removed as an assembly and kept intact.
7. The carburetor has a fuel return line connected via the fuel pump. The fuel return system will remain intact by using the original from the source below the intake manifold and connecting it to the return fitting on the fuel pump. (Unmarked fitting)
8. Disconnect the evaporative emission lines from the carburetor and air filter at the charcoal canister.
9. Disconnect the EGR valve and the thermal switch next to it they will be disconnected and not be used.
10. Plug the water choke hose on the rear tee of the intake manifold with the 8mm barb supplied.
11. Remove the two exhaust tubes from the exhaust manifold and use the 1/4" plugs supplied to plug the holes.
12. Plug all open vacuum and thermal switch fittings on the intake manifold. Make **ABSOLUTELY SURE** there are no connections to the EGR the only vacuum used is for the power brakes.
13. Loosen the 4 12mm carburetor mounting bolts, and the 10mm nut on the carburetor flange. Then remove the stock carburetor.
14. Insert shop towel into manifold opening before cleaning carburetor mounting surface. Clean carburetor mounting surface.

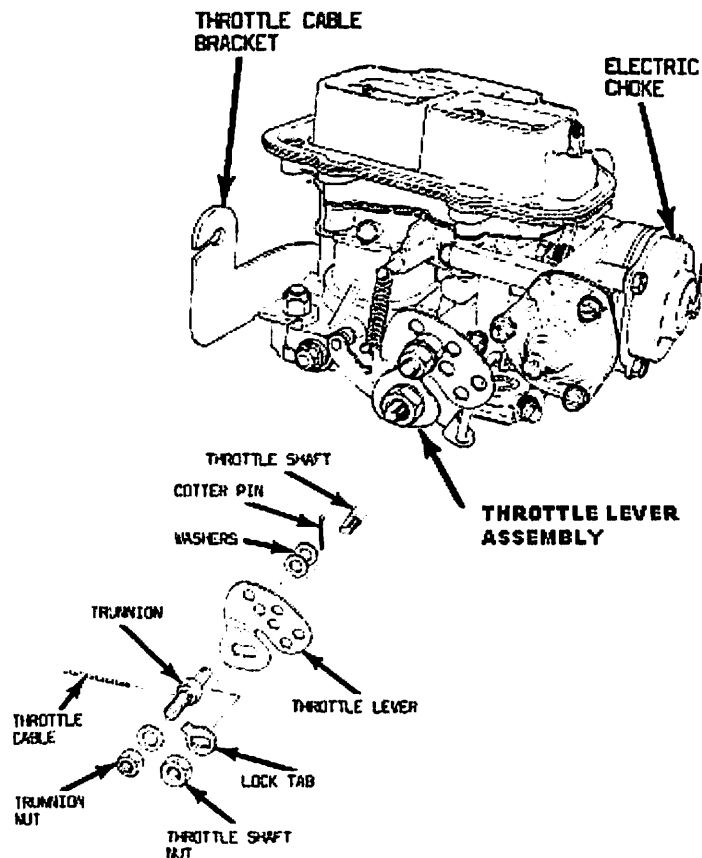

Bench assembly

Install the new REDLINE lever on the carburetor. **CAUTION: Do not over tighten throttle shaft nut.** Proper tightness can be achieved by installing nut just slightly more than finger-tight (finger tight then one more flat of the nut) and bend lock tab. After tightening, open choke and check for full throttle operation from idle stop to wide-open throttle. If any sticking or binding occurs, loosen nut and re-tighten with reduced torque. If excessive torque has been applied, re-centralization of the throttle plate may be necessary. This may require loosening nut and rapping on the end of the shaft with a small plastic mallet or a screwdriver handle (We are not driving nails here firm, but not abusive).

Reassembly

15. Remove rag from manifold opening. Install the carburetor adaptor as follows; (Use Loctite on all bolts and studs during installation of adaptor.)
 - a. Select the gasket that matches the intake manifold carburetor-mounting surface and coat it with grease or a suitable gasket sealer (Silicone or RTV is NOT suitable). Install the universal adaptor noting the position of the carburetor for the cable operation. Torque nuts to 12 ft. lbs.
 - b. Install the 8mm studs with the kit into the top adaptor half. Hand tighten these studs.
 - c. Set the carburetor base gasket over the studs on the adaptor. Install the Weber carburetor onto the adaptor and gasket. Install the throttle cable bracket on the two mounting studs opposite the choke housing. Install washers and nuts supplied. Torque the carburetor nuts to 12 ft. lbs.
 - d. Cycle the linkage by hand to check for sticking or binding. Remember over tightening causes binding. **Correct any linkage problems now before proceeding.** NOTE: the automatic choke will be set in the cold start position and unless the choke plate is held open the throttle will not return to the fully closed position.
16. Install the three position throttle lever with the holes towards the top of the carburetor following the directions in the bench assembly instructions.
17. Install the carburetor to the adaptor with the linkage toward the front of the vehicle and tighten to 12 ft lbs.
18. Use a "keyed" 12 volt source to connect to the choke and the idle cutoff valve
19. Connect the throttle cable bracket to the valve cover and connect the throttle cable to the linkage. Check for full throttle position and free throttle movement. If there is any throttle bind correct the problem before proceeding.
20. Connect the fuel line from the pump to the carburetor with the supplied hose.
21. Connect the vacuum advance port to the distributor with the supplied hose.
22. Re-connect battery and replace the fuel cap.
23. START ENGINE
 - a. Check for vacuum leaks around the carburetor-mounting base and correct as necessary. Use spray can of carburetor cleaner with hose attachment to isolate a leak, by spraying around carburetor mounting base. If any of the spray is entering the induction system, the idle speed will change. Note: Some leakage at the throttle shaft is expected.
 - b. If engine has poor idle, or will not idle at all, shut engine off and re-set idle by setting the Idle Speed Screw to 1 ½ turns in maximum after contact with the throttle lever. The Mixture Screw after lightly seating it comes out 2 turns. See tuning procedure page 5 & 6.

24. STOP ENGINE

- a. To install air filter assembly remove the four studs in the carburetor flange. Install the gasket and use the appropriate bolts or nuts (supplied with air filter) to secure to the carburetor. Connect new valve cover vent line using hose and clamps.

25. Check for adequate hood clearance before closing hood.

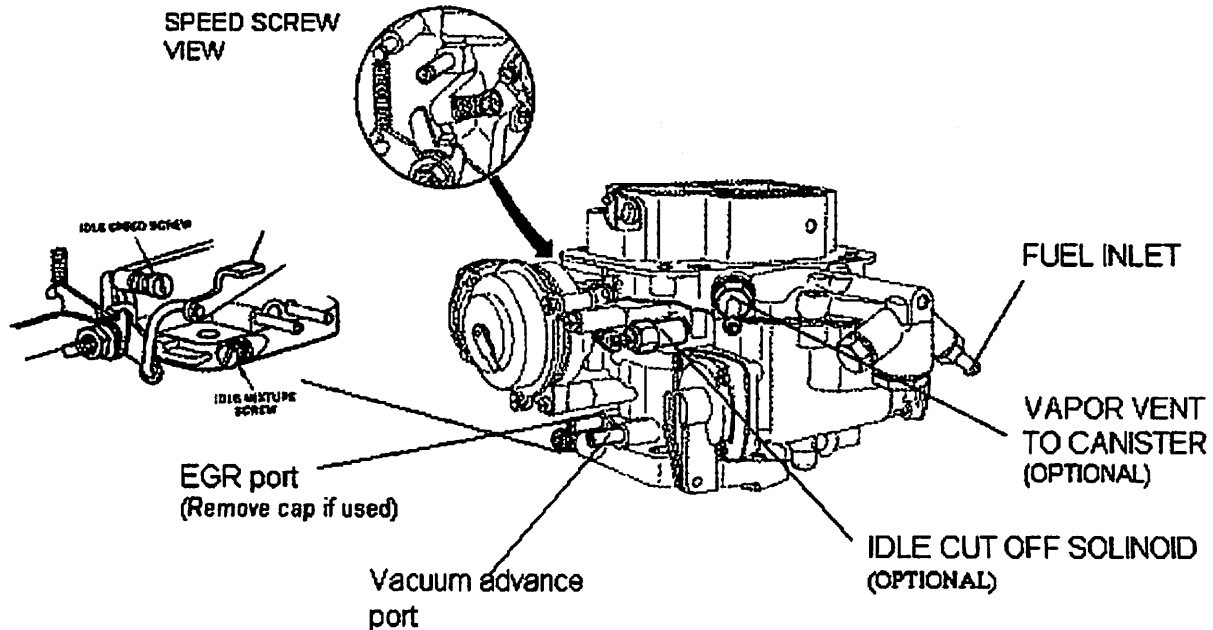

REDLINE WEBER Model DGV/DGEV FAST IDLE ADJUSTMENT

With the engine warmed up and turned OFF, open the throttle and manually engage the choke plates (butterflies). Release the throttle, then release the choke plates. The fast idle cam should now be activated and the fast idle speed screw should be positioned on the cam shoulder. Start the engine **DO NOT DEPRESS THE THROTTLE PEDAL OR THE CHOKE WILL BECOME INOPERATIVE**. To adjust the fast idle speed screw "in" (clockwise) to increase speed and "out" (counterclockwise) to decrease the speed.

TECH SUPPORT

We offer free technical support service for the first 90 days after your purchase of this conversion kit. Provide us with, the kit part number and the production code on the label on the outside of the box.

Additional assistance for special performance tuning AND non-warranty service is available for a fee, based on each problem resolution and the service charge will be confirmed at the time of the call, if applicable.

All Warranty and technical assistance is provided through the manufacture, REDLINE. No part will be credited or exchanged through the retailer.

ALL technical support and warranty issues will be handled through the manufacture REDLINE / WEBER @ 1-800-733-2277 ext 7457.

32/36 Progressive

Lean Best Idle Adjustment



Base line Settings

Speed Screw 1 to 1 1/2 turns **MAXIMUM**

Mixture Screw 2 turns

Your settings with engine running

Speed Screw _____

Mixture Screw _____

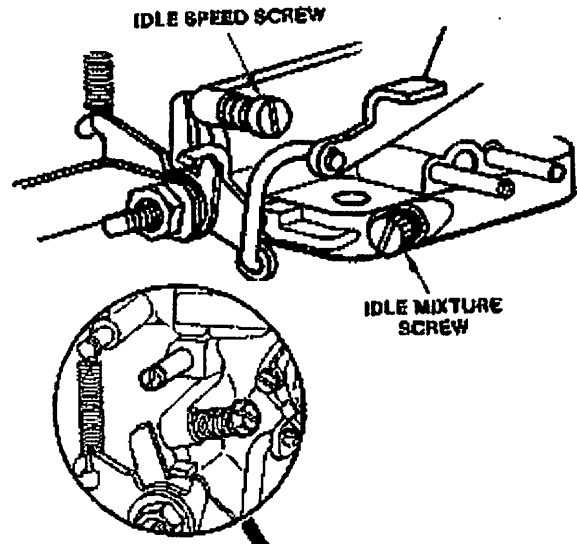

It is important to verify all linkage and levers are installed without binding and the linkage opens to full throttle and closes to the Idle Speed Screw. The number one and two reasons for tuning errors are improper linkage installations and over tightened linkage nut, causing a binding in the linkage assembly.

All settings are done with engine warmed up so that the choke is fully opened and disengaged.

1. Back out the Idle Speed Screw until it does not touch the throttle lever. Cycle or Snap the linkage again to be sure that the linkage and lever comes to complete close. (Checking for linkage bind) Turn in the idle speed screw until it contacts the throttle lever, and then continue to turn the idle speed screw in 1 1/2-turn maximum.
2. Set the Idle Mixture Screw by turning it in until it lightly seats. Then back out the mixture screw 2 full turns out. **DO NOT FORCE THE MIXTURE SCREW, AS THIS WILL CAUSE DAMAGE TO THE SCREW AND ITS SEAT IN THE BODY OF CARBURETOR.**
3. * With the engine at operating temperature, choke fully open and engine running, turn in the mixture screw until the engine starts to run worse, then back out the screw (recommend 1/4 turn at a time) until the engine picks up speed and/or begins to smooth out. Back out 1/4 turn more, or until the screw does nothing or runs worse then turn back to the point where it ran its best. We are looking for the Lean Best Idle or the "sweet spot".
4. Recheck timing and vacuum hook ups. Then, recheck mixture screws to lean best idle again. If all is still the sweet, best and smoothest idle then confirm and note the final settings.
5. If the mixture screw is out more than 2 1/4 turns, then the idle jet is too lean (too small). If the mixture screw is out 1 3/4 of a turn or less, then the idle jet is too rich (too large).

These assumptions are based on the fact that the Idle Speed Screw is not more than 1 1/2 turns in. If the Idle Speed Screw has to be opened more than 1 1/2 turns then this is also an indication of a lean condition usually requiring jet change. "At times" it may appear to be showing signs of richness or flooding this could also be the float level is too high, 17mm from gasket surface to the tip of the float, and, check the fuel pressure, MAX. 3 1/2 PSI, USE a pressure regulator!

REDLINE WEBER



LOW SPEED CIRCUIT

"Where Performance Begins"

**TECH
SERIES**

WEBER Carburetors are smart. Unlike any other in the world. A WEBER can be fine tuned to perform almost any way you want. Try tuning a WEBER like other carburetors—it generally won't react the way you expect. So in order to gain the most performance, power and overall efficiency—understanding the difference is vital.

55 MPH CRUISE AT IDLE!

WEBERS are really two carburetors in one. Each independently covers their part of the operating range. Even though the first is naturally called the "IDLE CIRCUIT"—in a WEBER it is actually the LOW SPEED CIRCUIT and controls a very broad range of performance. It's also the most important difference. Other carburetors are designed to rush into the high speed circuit. WEBER thinks this approach wastes fuel and is less manageable. WEBERS are designed to efficiently operate in the LOW SPEED CIRCUIT until the engine really needs high volumes of fuel. It is this precise management of fuel and air, at critical RPMs, that promotes the exceptional throttle response and fuel economy associated with a properly tuned WEBER carburetor.

WHEN IS A MIXTURE SCREW NOT A MIXTURE SCREW?

Until they're WEBER-WISE most mechanics will swear our IDLE VOLUME ADJUSTING SCREW is the same as the familiar air bleed/mixture screw found on other types of carburetors. It's a natural misunderstanding. They almost look the same. Our IDLE SPEED FUEL JET is also mistaken for a simple air bleed. It is in fact the heart of the WEBER LOW SPEED CIRCUIT—a changeable mini



Idle Speed Fuel Jet

- IDLE SPEED AIR JET
- IDLE SPEED FUEL JET
- IDLE SPEED ADJUSTER SCREW
- TRANSITION PORTS
- IDLE VOLUME SCREW

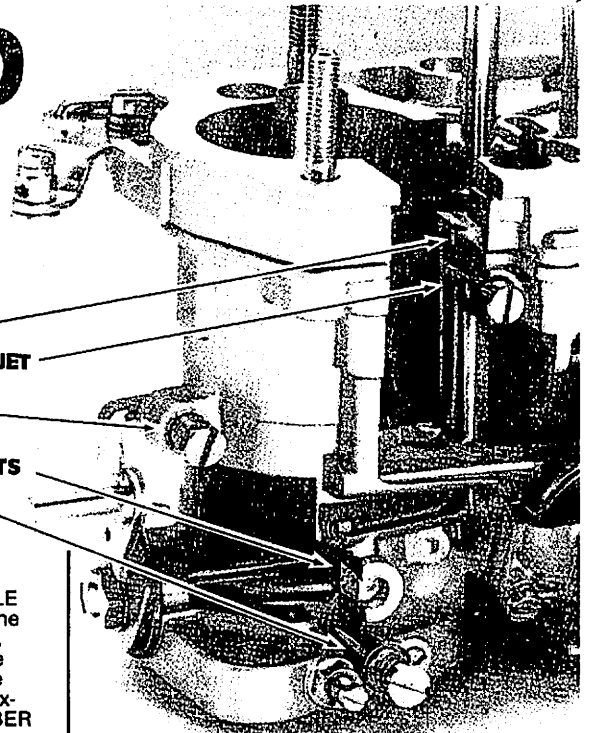

jet, air bleed and emulsion tube that precisely premixes fuel and air. The IDLE VOLUME SCREW actually distributes the premixed fuel/air mixture to the engine. Other carburetors rely totally on coarse threaded adjuster screws that open the butterflys to control idle speed and mixture. Only the tapered edge of the WEBER IDLE VOLUME SCREW gives your customers virnler-like management of complete mixture and engine speed.

TRANSITION: SLOTS AND BIG HOLES—GREAT PERFORMANCE DO NOT MAKE!

Instead of a slot or indiscriminately placed progression holes, WEBER chooses closely defined TRANSITION PORTS positioned in the lower part of the throttle bore to ensure smooth engine operation during throttle opening stages. Most manufacturers that mass-produce carburetors today use slots or several large holes because they can be easily cast into the carburetor. It seems they are willing to let your customers pay the price of reduced performance for their convenience. We're not. Our TRANSITION PORTS are precisely located and individually positioned in a fully machined bore. Port location is critical. The ports must correspond to the exact position of throttle plate's beveled edge. There is absolutely no room for sloppy manufacturing of the WEBER carburetor. The construction process often requires extra steps—but we believe the results are incredibly important to those that demand uncompromised performance.

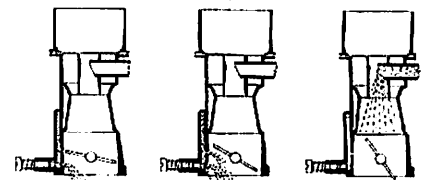

A Idle Circuit operation

B Transition Stage

C Priming of the main circuit/Idle circuit cut-off

COPIES DON'T WORK AS WELL AS THE ORIGINALS!

It's been more than 70 years since WEBER developed the criteria for many of the now popular carburetor styles. In some cases with our blessing, a number of companies make their own version of the original design. Either because of mass production techniques or difference in basic philosophy—the WEBER carburetor is the clear performance choice in open racing competition and specific street applications.

Legal in California for racing vehicles which may never be used upon the highway.

WEBERS ARE FOR WINNERS!

You can bet WEBER-WISE Champions like "Mike Gillman, Ivan Stewart and the TOYOTA RACING TEAM" understand and rely on the WEBER attention to detail and subtlety of design. WEBER...the overwhelming performance choice of winning racing teams—worldwide!

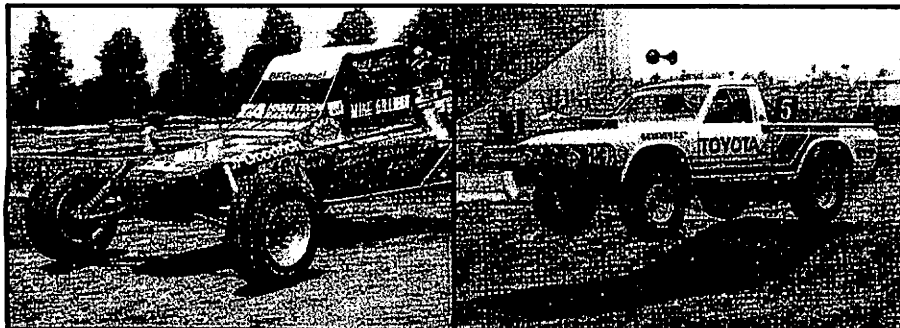
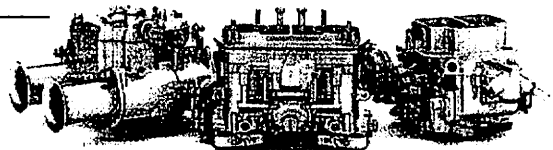

WEBER

Carburetor & Fuel Injection Specialists

REDLINE WEBER
19630 PACIFIC GATEWAY DRIVE
TORRANCE, CA 90502

Trouble shooting guide



This guide is intended for diagnostic purpose only. Specific procedures and adjustments should be obtained from factory service manuals or the carburetor specification sheet.

Every REDLINE Weber carburetor is thoroughly tested at the factory and meets high quality and performance standards.

Since other engine components problems affect the performance of the carburetor it is strongly recommended to perform the general engine checks of this guide BEFORE making any carburetor adjustments.

GENERAL ENGINE CHECKS

IGNITION SYSTEM

1. Cracked, broken wires
2. Incorrect ignition wire location (firing order)
3. Timing improperly adjusted
4. Distributor cap cracked, arcing
5. Low coil output
6. Corroded plug terminals
7. Incorrect vacuum advance hose connection
8. Points corroded, wrong gap
9. Incorrect spark gap

EMISSION SYSTEM

1. Cracked, loose vacuum hoses
2. Improper vacuum hose connections
3. Faulty EGR valve operation
4. Air pump diverter valve anti-backfire valve faulty
5. Faulty PCV valve operation
6. Dirty breather filters (Charcoal canister, Valve cover breather, PCV filter inside air filter assembly)
7. Faulty feedback system operation
8. Vacuum delay valves (switches) faulty

FUEL SUPPLY SYSTEM

1. Dirty fuel filter
2. Incorrect fuel pump pressure (1.5 – 3.5)
3. Restricted, kinked fuel lines
4. Fuel lines in contact with hot surface
5. Contaminated fuel

SPARK PLUG ANALYSIS

Normal spark plug condition is a sandy brown deposit on the insulator surface with no signs of electrode damage. The following conditions will help you analyze your plugs condition.

OIL DEPOSITES – WET FOULING

1. Worn piston rings, bearings, seals
2. Excessive cylinder wear
3. Leaking- damaged head gasket

BLACK CARBON BUILD-UP, DRY FOULING

1. Fuel mixture too rich
2. Dirty air filter
3. Engine over heating
4. Defective ignition wires
5. Sticking valves, worn seals
6. High carburetor float level
7. Damaged, sticking needle and seat assembly
8. Incorrect fuel pump pressure (1.5 - 3.5)
9. Spark plug heat range to cold

BLISTERED, BURNED ELECTRODES

1. Spark plug range to hot
2. Timing improperly adjusted
3. Engine overheating
4. Incorrect spark plug gap
5. Burned engine valves
6. Wrong type of fuel

INSULATORS CHIPPED

1. Incorrect spark plug gap
2. Improper spark plug installation
3. Severe detonation

PLUG GAP BRIDGED

1. Lead deposits fused to electrode
2. Engine overheating
3. Spark plug heat range to hot

GASOLINE FOULING

1. Distributor cap cracked, arcing
2. Loose, broken ignition wires
3. Low coil output

Carburetor troubleshooting guide



This is a guide for diagnostic purposes only

ENGINE WILL NOT START

Over 90% of engine failure to start conditions are ignition system related

1. Open circuit between starter and solenoid, or between ignition switch and solenoid
2. Starter motor faulty
3. Battery charge to low

ENGINE HARD TO START WHEN COLD STARTS & STALLS

1. Incorrect choke operation (worn coil, electrical connection faulty)
2. Fast idle speed to low
3. Improper choke pull off operation
4. Low carburetor float level
5. Timing improperly adjusted
6. Damaged sticking needle and seat
7. Engine flooded

ROUGH IDLE, SURGING, MISSING, STALLING

1. Incorrect idle speed and idle mixture adjustment
2. Timing improperly adjusted
3. Vacuum leak
4. Incorrect vacuum advance hose connection
5. Faulty EGR valve operation
6. Faulty PCV valve operation
7. Incorrect choke operation (coil settings)
8. Improper choke pull off diaphragm operation
9. Improper vacuum hose connection
10. Low carburetor float level
11. Restricted, kinked fuel lines
12. Restricted fuel filter
13. Distributor cap cracked, arcing
14. Loose, corroded, or broken ignition wires
15. Damaged idle mixture adjusting screw
16. Distributor shaft worn
17. Faulty idle solenoid operation
18. Restricted carburetor jets or air bleeds
19. Restricted air, breather filters
20. Incorrect spark plug gap

ENGINE KNOCKS, PINGING

1. Timing improperly adjusted
2. Incorrect vacuum hose connections
3. Distributor malfunctions
4. Carburetor jets to lean, restricted
5. Low carburetor float level
6. Poor quality fuel
7. Faulty EGR valve operation
8. Faulty feedback system operation

ENGINE KNOCKS, PINGING (Cont.)

9. PCV system malfunction
10. Loose fan belts
11. Faulty vacuum delay valve (switch)

DIESELING, ENGINE RUN ON

1. Faulty idle solenoid operation
2. Carburetor linkage binding
3. Incorrect idle speed and idle mixture adjustment
4. Timing improperly adjusted

HESITATION, POOR ACCELERATION, FLAT SPOT

1. Vacuum leaks
2. Improper vacuum hose connections
3. Timing improperly adjusted
4. Low carburetor float level
5. Loose, corroded or broken ignition wires
6. Low ignition coil output
7. Fouled or damages spark plugs
8. Incorrect accelerator pump operation
9. Incorrect fuel pump pressure (1.5 – 3.5)
10. Restricted or kinked fuel lines
11. Restricted fuel filter
12. Carburetor power enrichment system malfunction

POOR LOW SPEED OPERATION

1. Indirect idle speed and idle mixture adjustment
2. Dirty air filter
3. Timing improperly adjusted
4. Loose, corroded, or broken ignition wires
5. Distributor cap cracked or arcing
6. Restricted idle jets or air bleeds
7. Incorrect carburetor float level

POOR HIGH SPEED OPERATION

1. Incorrect vacuum advance hose connection
2. Incorrect distributor centrifugal advance
3. Incorrect spark plug gap
4. Incorrect carburetor main jets, air correctors
5. Incorrect vacuum hose connections
6. Dirty air, or breather filters
7. Incorrect fuel pump pressure (1.5 – 3.5)
8. Worn distributor shaft
9. Incorrect carburetor float valve
10. Incorrect carburetor float level
11. Restricted or kinked fuel lines
12. Restricted fuel filter

Typical REDLINE WEBER kit

The parts will vary from kit to kit. Shown below is a typical installation kit with two piece adapter. Also included are fuel hose, chrome air filter and all mounting hardware. Not shown are general installation instructions and tuning information.

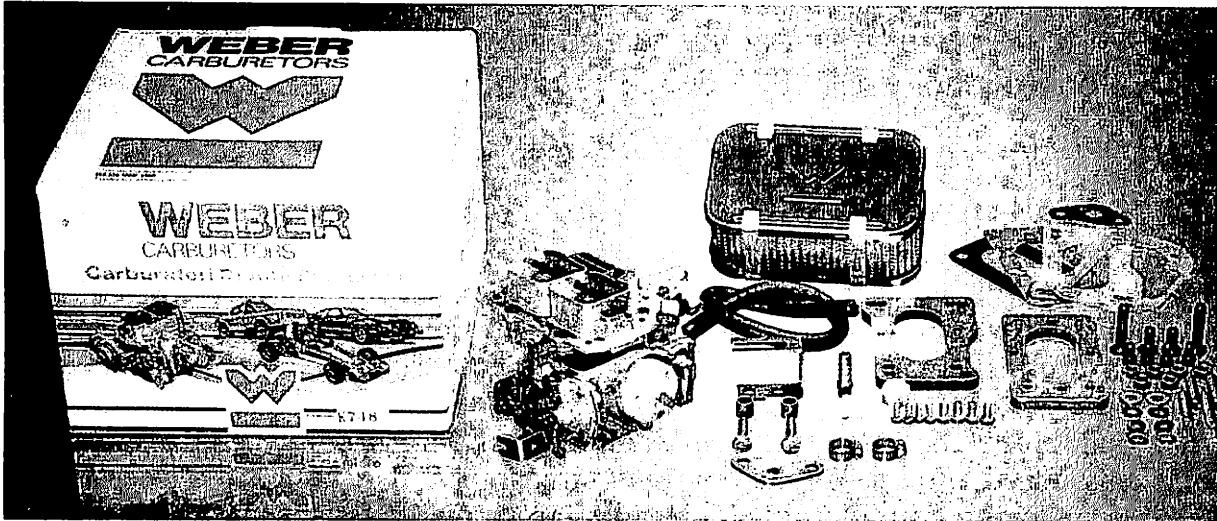

Accessories:

Performance / Altitude Jet kit for 4 cyl. and 6 cyl. engines.
701-DGV4 4cyl, 701-DGV6 6cyl DGEV.
701DGS, 38DGES Outlaw

Filters:

2 5/8" chrome filter: 99217.332S
Element only: 99400.292
Filter Clips (4): 99217.000S

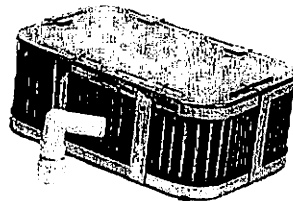

Universal Air Filter Adapter: 99010.457

To mount traditional high performance filter

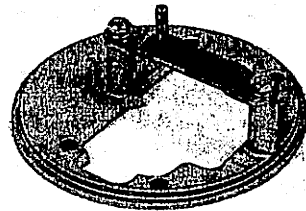

Remote Air Filter Snorkel Kit: 99010.357

This kit allows you to move the air filter to a remote location or above the water line for the tough river forge or just to get the filter out of the dust and mud Zone into the passenger compartment or up on the roll bar.

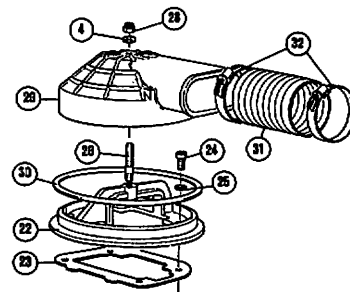

Making The Right Choice

32/36 mm progressive or 38 mm Synchronous

Facts and Information

In the past there have been questions and much miss information put out on the choice of a 32/66 DGEV carb or the 38 DGAS.

To help make the right choice for your future needs.

- 1) **The Kits utilizing the 32/36 Progressives Weber are designed to provide the aftermarket with an economical performance carburetor conversion that while increasing HP also improves drivability and fuel economy over the original stock carburetor. REDLINE kit's using the 32/36 progressive carburetor is the optimum carburetor for use as a performance replacement carburetor for a worn out or hard to maintain factory carb.**
- 2) **When purchased in kit form the Redline Weber 38mm DGAS carburetor will perform very well on a stock unmodified engine. This is not an over carbureted situation. The REDLINE kit will provide considerably more initial torque and acceleration. The top end performance will not be significantly improved over the 32/36 when used on a stock engine.**
- 3) **The 38mm DGAS carburetor should be the only consideration if the engine has been modified, or, in the future will have any level of additional engine modifications. Such as headers, free flowing exhaust, a cam, or rebuilt engine. Usually these rebuilt engines will be improved over the stock engines with oversize pistons and towing cam. The REDLINE 38 DGES will enhance the/your engine improvements/modifications. The 6 cylinder engine applications are particularly enhanced by this application. In-fact, ALL JEEP and LANDCRUSER applications with any upgrades this is a mandatory choice in carburetors.**
- 4) **When using a 32/36 DGEV with the same above modifications will require additional calibration and re-jetting to attain the limited performance improvements. There is a jet kit available for just this reason. The re-jetting is required due to the performance enhancements of the additional items usually requiring more fuel. Although the 32/36 DGEV does out perform the original, to receive the full benefit of your modifications will require helpful re-calibration. The 38 DGES on the other hand is the optimum choice and has a larger fuel delivery system and the calibration to handle the broader range of improved performance and will substantially improve your other product investments.**
- 5) **While the 32/36 DGEV progressive carb should improve your fuel economy and performance on a stock engine compared to the OEM carb. The 38 DGES Synchronous carb will not get less fuel economy than the OEM carb and will improve initial torque and acceleration.**

RECAP:

The 32/36 DGEV progressive carburetor as used in any Redline Weber kit is pre-calibrated and set to run on most normal standard and stock engines and provide some performance and fuel economy improvements. If that engine has been upgraded or improved with other performance items there will be a need to recalibrate and re-jet the carburetor in most situations. There is a performance jet kit for the 32/36 DGEV applications Pt No. 701-DGV4 or 701-DGV6.

The REDLINE Weber kit with the 38 DGAS synchronous carburetor is also pre-calibrated for use on stock and modified engines and is not over carbureted. It also provides the best starting point for engines that are ultimately going to be upgraded with additional performance items with performance over fuel economy being the ultimate goal. For re-jetting the 38 DGES use jet kit 701DGS.

32/36 DGEV

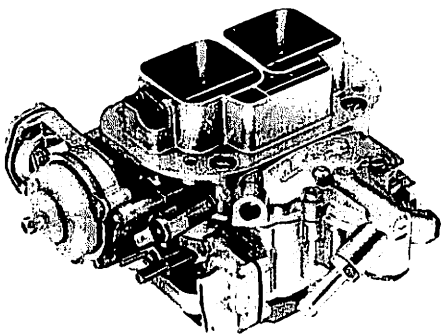

Progressive Series carburetor

22680.005	Manual choke
22680.051B	Water choke
22680.033B	Electric choke

38 DGES Outlaw

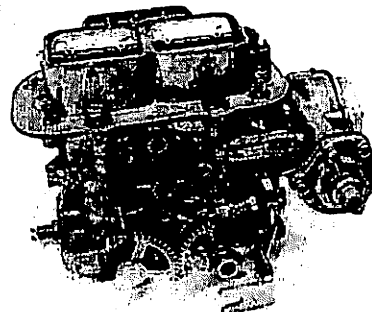

Synchronous Series carburetor

18930.032	Water choke
18930.020	Electric choke