

## FRONT WHEEL ALIGNMENT

### 1. MEASURE VEHICLE HEIGHT

Front vehicle height:

A-B=58.5 mm(2.303 in.)

A:Height at center of tip of steering knuckle

B:Height at center of tip of front side adjusting cam bolt

**NOTICE:** Before inspecting the wheel alignment, adjust the vehicle height to specification.

**HINT:**With non-loaded vehicles, there is a difference in the vehicle height according to the model.

Although the wheel alignment standard value changes according to the vehicle height, by setting the vehicle height to the standard height the standard alignment value becomes the same for all models.

For the vehicle height of non-loaded vehicles for each model and the alignment standard values, refer to page [SA-179](#).

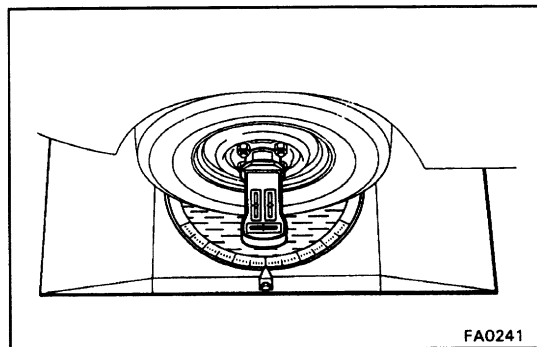

### 2. INSTALL CAMBER - CASTER - KINGPIN GAUGE OR ONTO WHEEL ALIGNMENT TESTER

Follow the specific instructions of the equipment manufacturer.

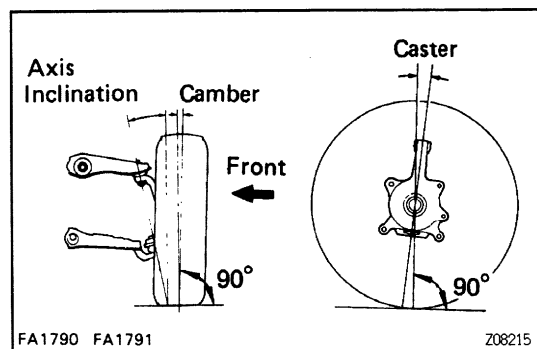

### 3. INSPECT CAMBER, CASTER AND STEERING AXIS INCLINATION

**Camber:**

$0^{\circ} 45' \pm 45'$

**Steering axis inclination:**

$11^{\circ} 50' \pm 45'$

**Caster:**

$2^{\circ} 30' \pm 45'$

If the steering axis inclination is not as specified after camber and caster have been correctly adjusted, re-check the steering knuckle and front wheel for bending or looseness.

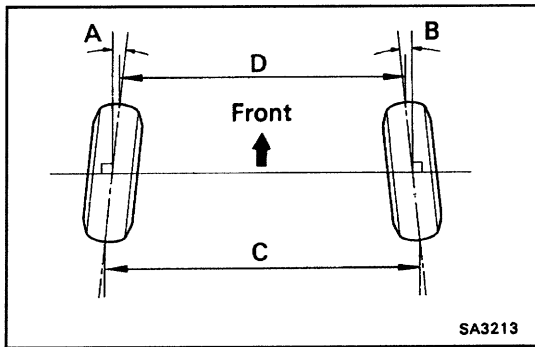

#### 4. INSPECT TOE-IN

Toe-in:

$$\text{Toe-in} = B - A$$

Toe-in:

$$1 \pm 2 \text{ mm } (0.04 \pm 0.08 \text{ in.})$$

If toe-in is not within specification adjust by the tie rod end.

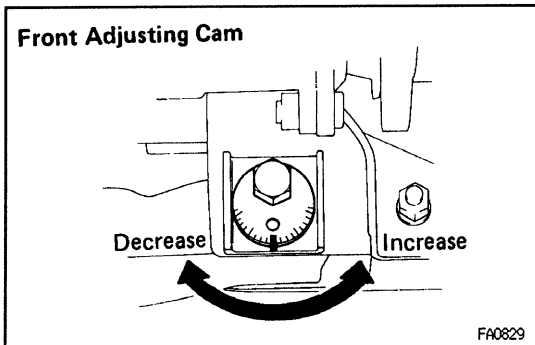

#### 5. ADJUST CAMBER AND CASTER

If camber and/or caster are not within specification, adjust by front and/or rear adjusting cams. (See page SA-8 Adjustment Chart)

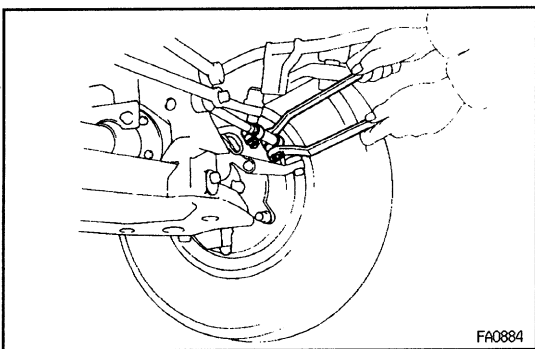
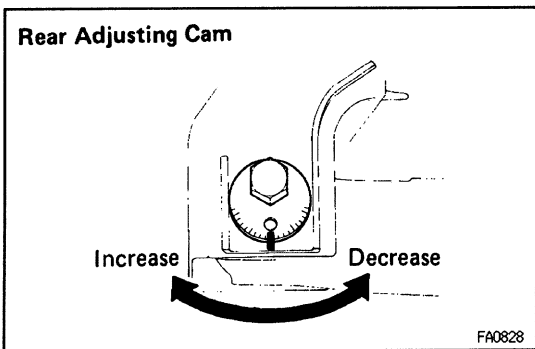

#### 6. ADJUST TOE-IN

(a) Loosen the clamp bolts and nuts.

(b) Adjust toe-in by turning the left and right tie rod tubes an equal amount.

Toe-in :

$$1 \pm 1 \text{ mm } (0.04 \pm 0.04 \text{ in.})$$

(c) Insure that the lengths of the left and right tie rods are equal.

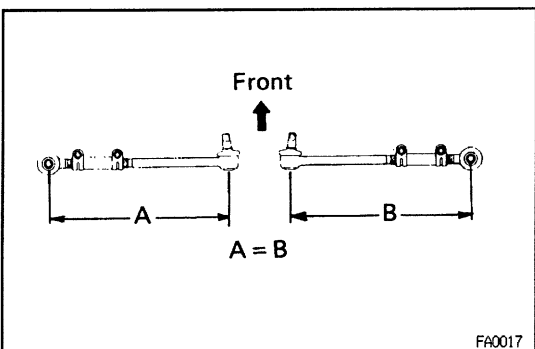

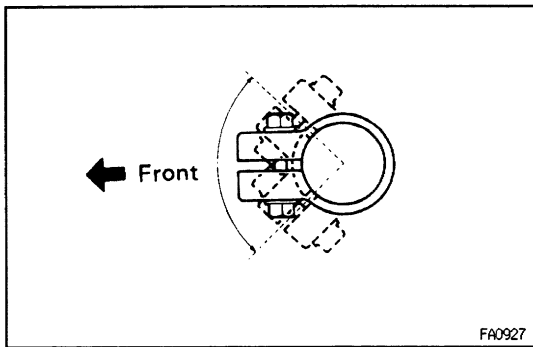

(d) Torque the clamp bolts and nuts.

**Torque: 22 N-m (225 kgf-cm, 16 ft-lbf)**

HINT: Face the clamp bolt toward the front of the vehicle.

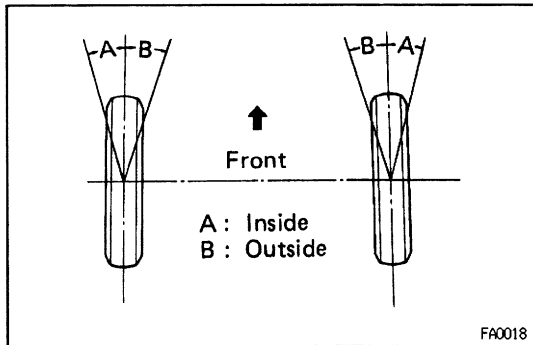

## 7. INSPECT WHEEL ANGLE

Remove the caps of knuckle stopper bolts and check the steering angles.

Wheel angle:

Item	Inside wheel	Outside wheel (Reference)
Maximum	32°00' (30°00' ~ 33°00')	31°
At 20°	21°10'	20°

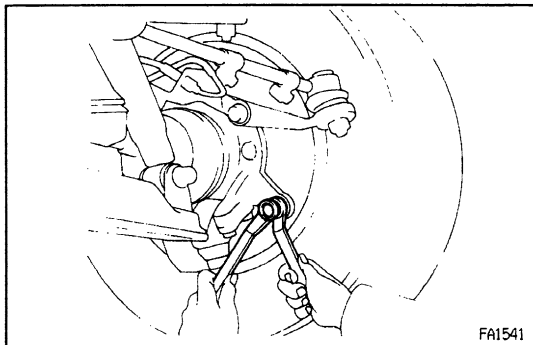

HINT: When the steering wheel is fully turned, make sure that the wheel is not touching the body or brake tube.

If maximum steering angles differ from standard value, adjust the wheel angle with the knuckle stopper bolts.

**Torque: 47 N-m (480 kgf-cm, 35 ft-lbf)**

If the wheel angle still cannot be adjusted within limits, inspect and replace damaged or worn steering parts.

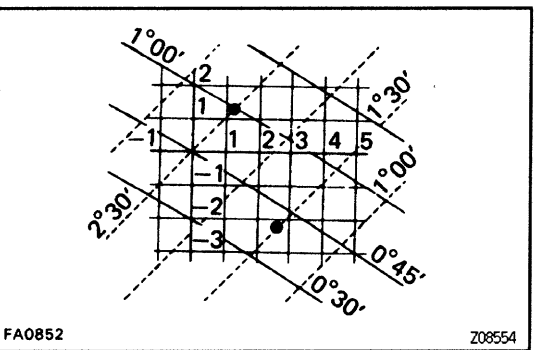
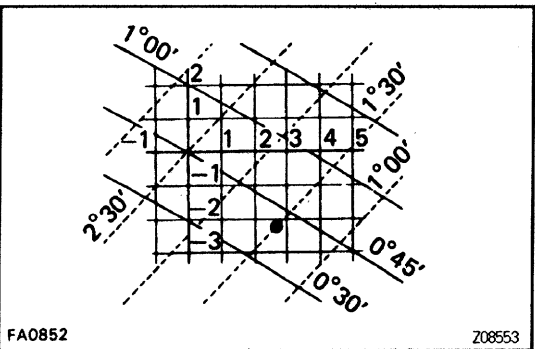
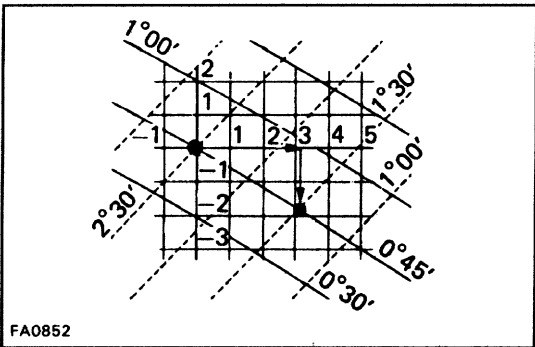
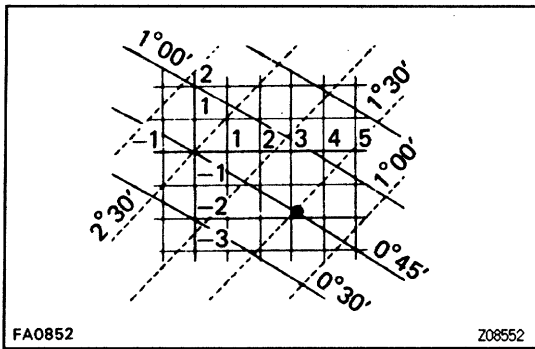

## HOW TO READ ADJUSTMENT CHART

### 1. ALIGNMENT MEASURED WITH VEHICLE HEIGHT SET TO STANDARD HEIGHT FOR WHEEL ALIGNMENT INSPECTION

- (a) Mark on the adjustment chart the alignment values measured with the vehicle at standard height.

**Example:**

**Camber 0°45'**

**Caster 1°30'**

- (b) To calculate the amounts by which the front and/or rear cams are to be adjusted, read from the adjustment chart the distance from the center of the chart to the mark you have made, as shown in the illustration.

**Example:**

**Front cam -1.8**

**Rear cam +3.1**

- (c) Torque the front and/or rear cam nuts.

**Torque: 196 N-m (2,000 kgf-cm, 145 ft-lbf)**

### 2. WHEEL ALIGNMENT MEASURED AT VEHICLE HEIGHT OF NON-LOADED VEHICLE

- (a) Find the wheel alignment standard value applicable for the particular model in non-loaded condition.

(See page [SA-179](#))

- (b) Mark the selected standard value on the adjustment chart.

**Example:**

**Camber 0°40'**

**Caster 1°30'**

- (c) Mark on the adjustment chart the alignment values measured at the non-loaded vehicle height.

**Example:**

**Camber 1°00'**

**Caster 2°30'**

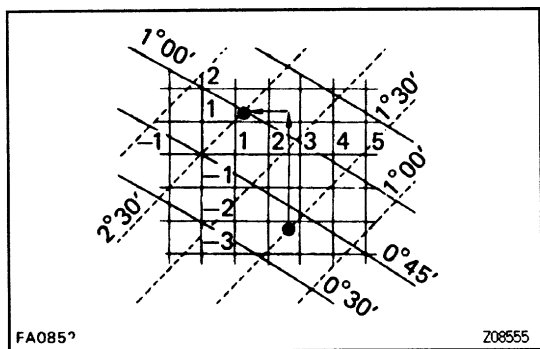

(d) As shown in the illustration, read the distance from the standard value to the measured value, and adjust the front and/or rear adjusting cams accordingly.

**Example:**

**Front cam +3.4**

**Rear cam -1.6**

(e) Torque the front and/or rear cam nuts.

**Torque: 196 N-m (2,000 kgf-cm, 145 ft-lbf)**

**Adjustment Chart**

————— Camber  
 - - - - - Caster

