

# 1 4RUNNER ELECTRICAL WIRING DIAGRAM

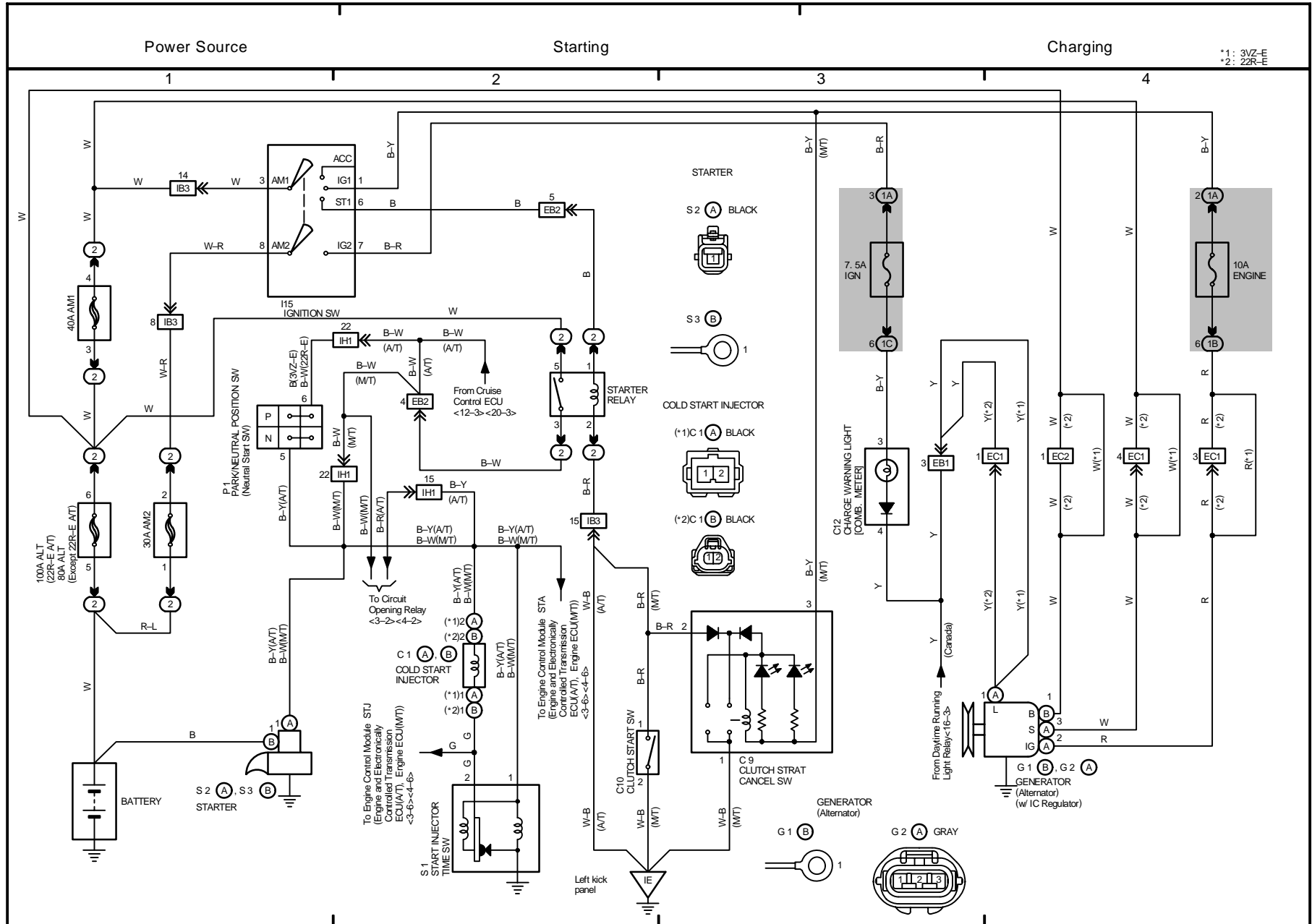

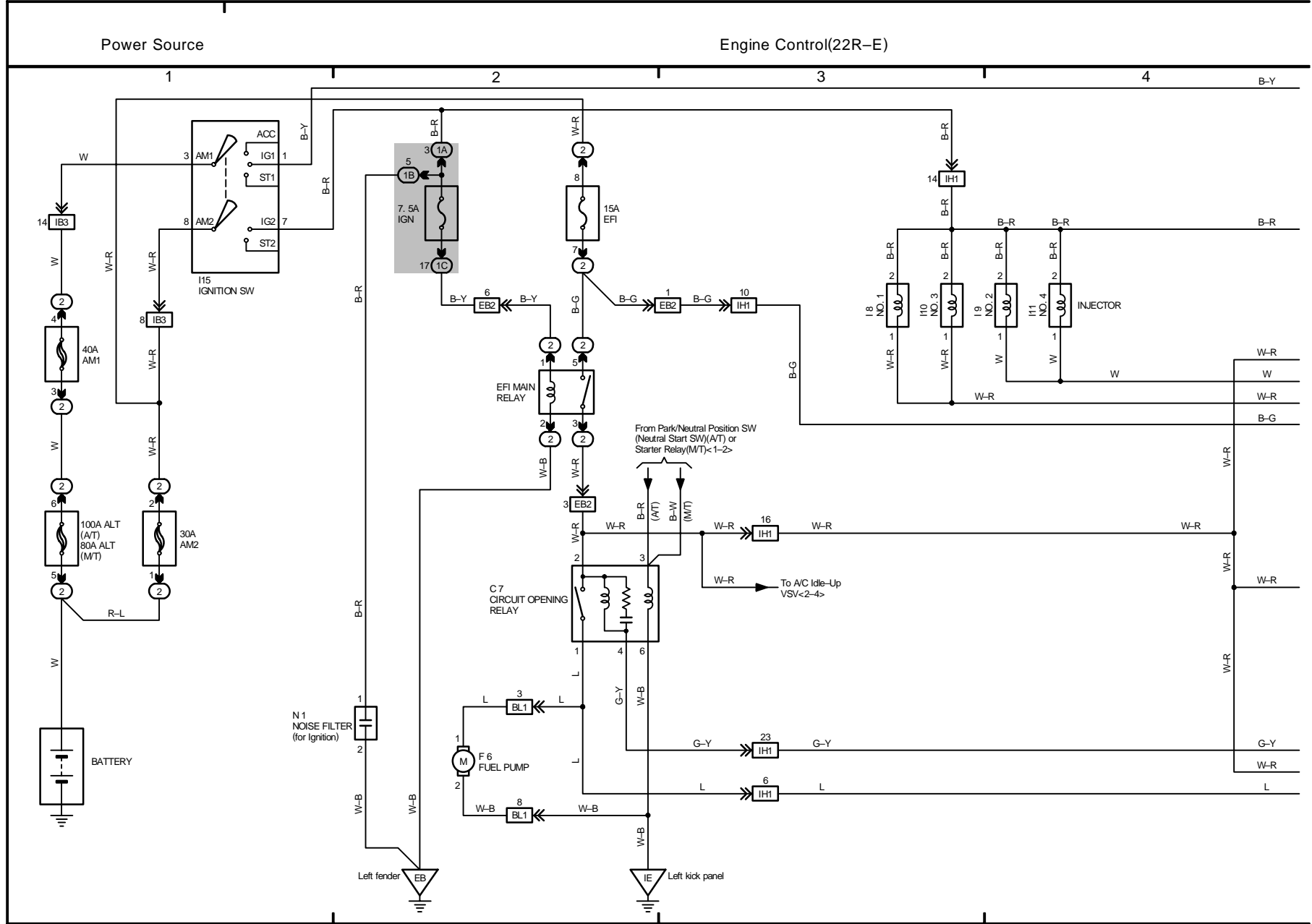





### 3 4RUNNER (Cont'd)

#### Engine Control(22R-E)

\*1: California  
\*2: Shielded

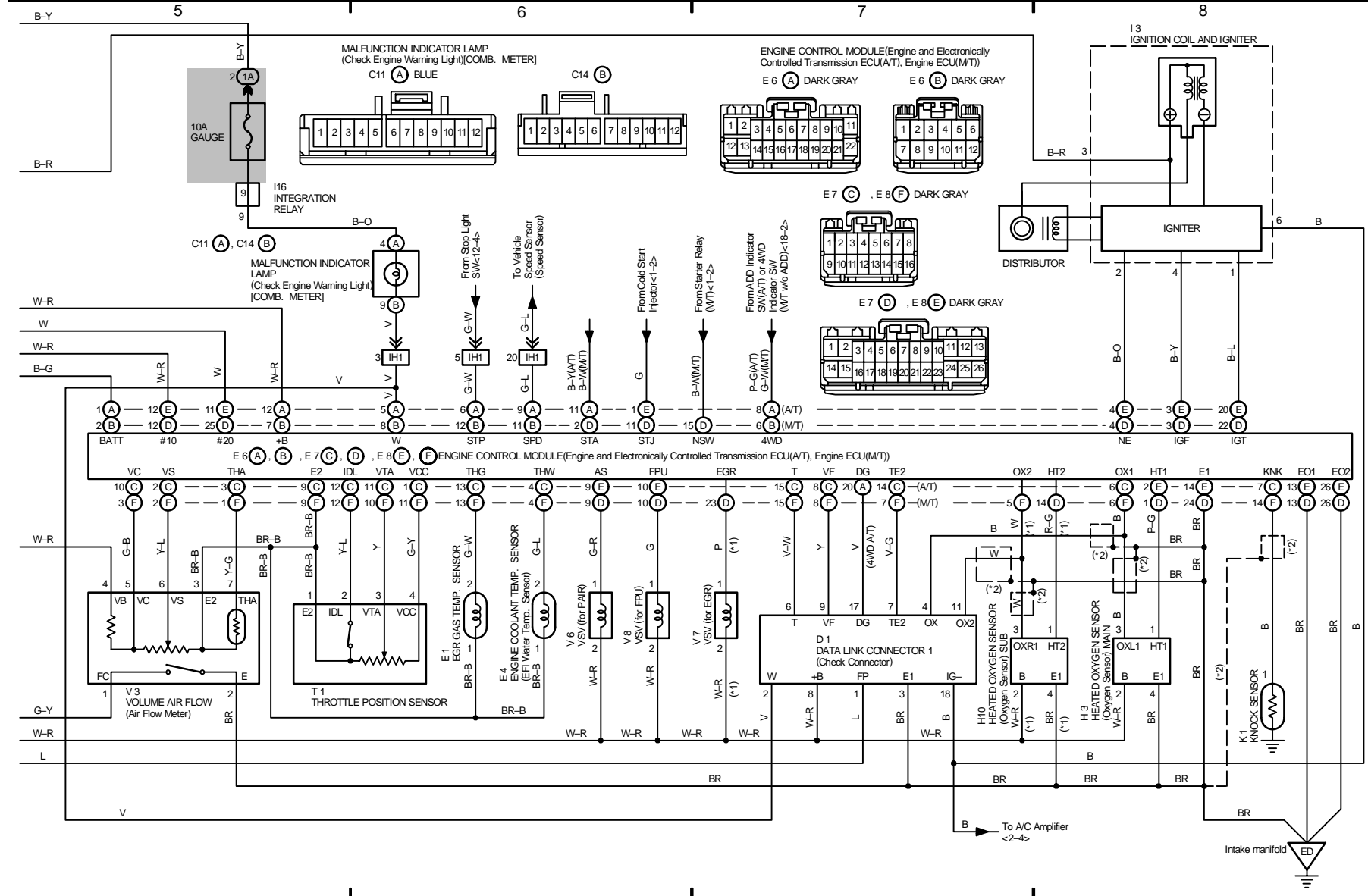





# OVERALL ELECTRICAL WIRING DIAGRAM

## 5 4RUNNER

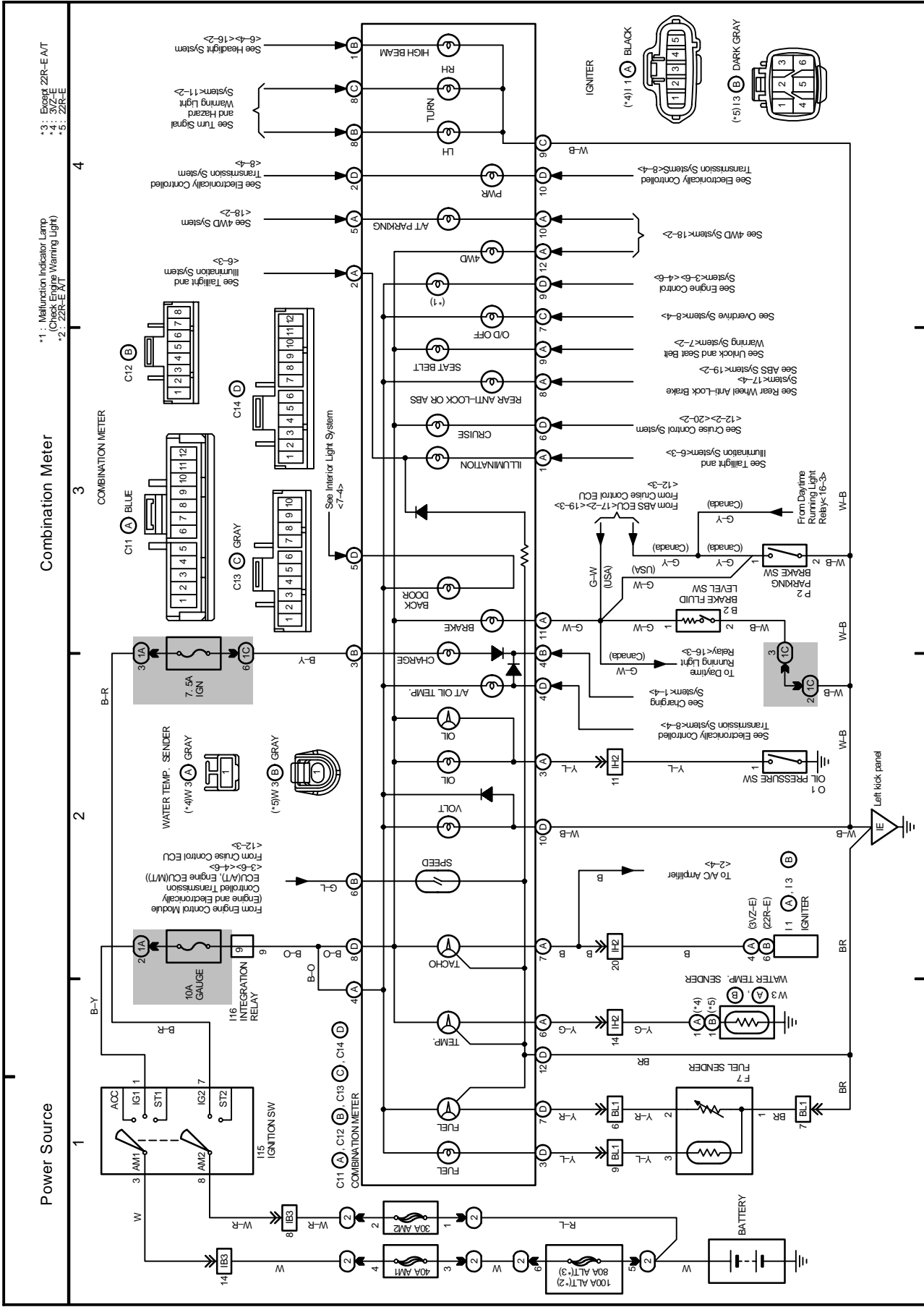

# 6 4RUNNER

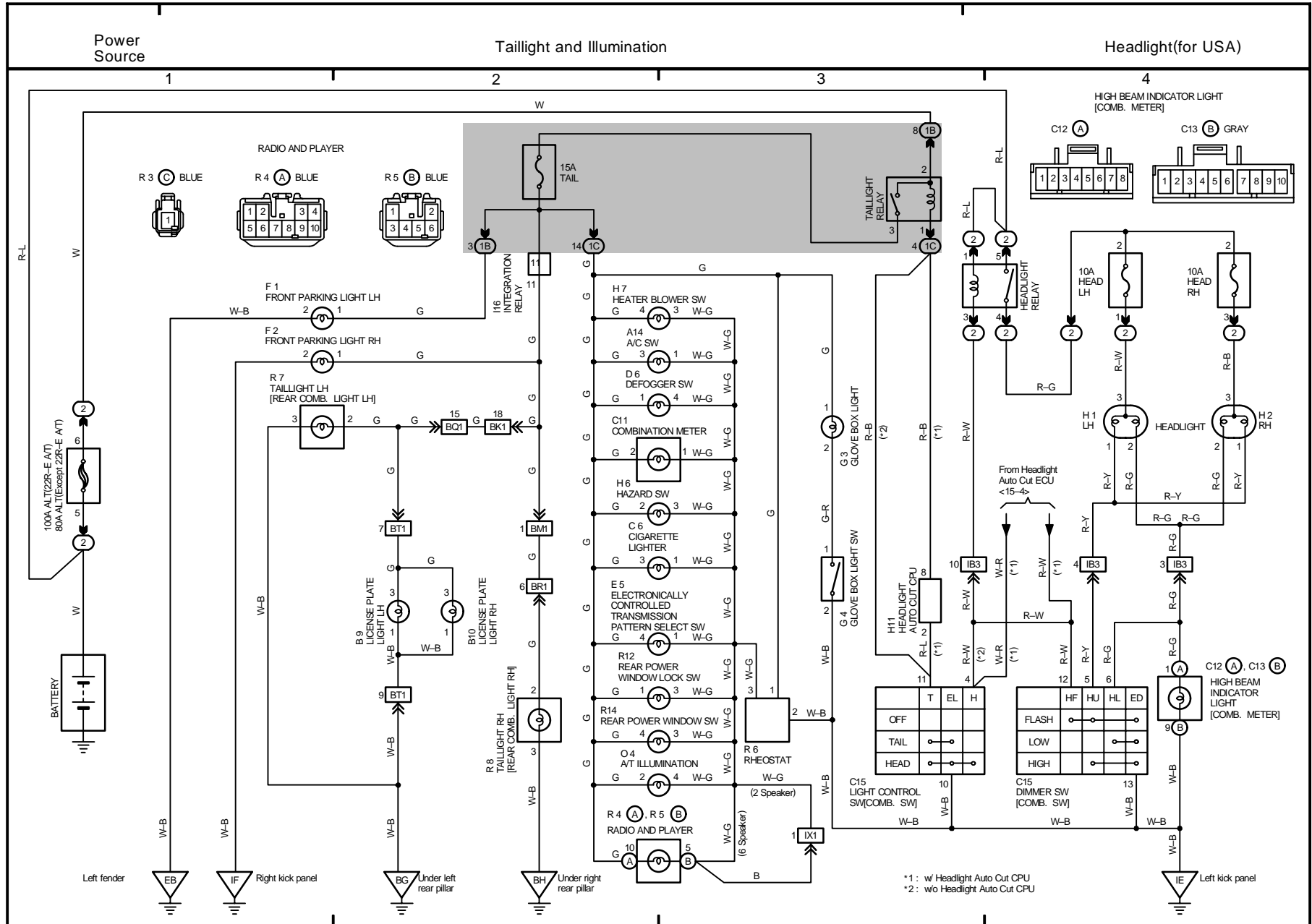



# 8 4RUNNER

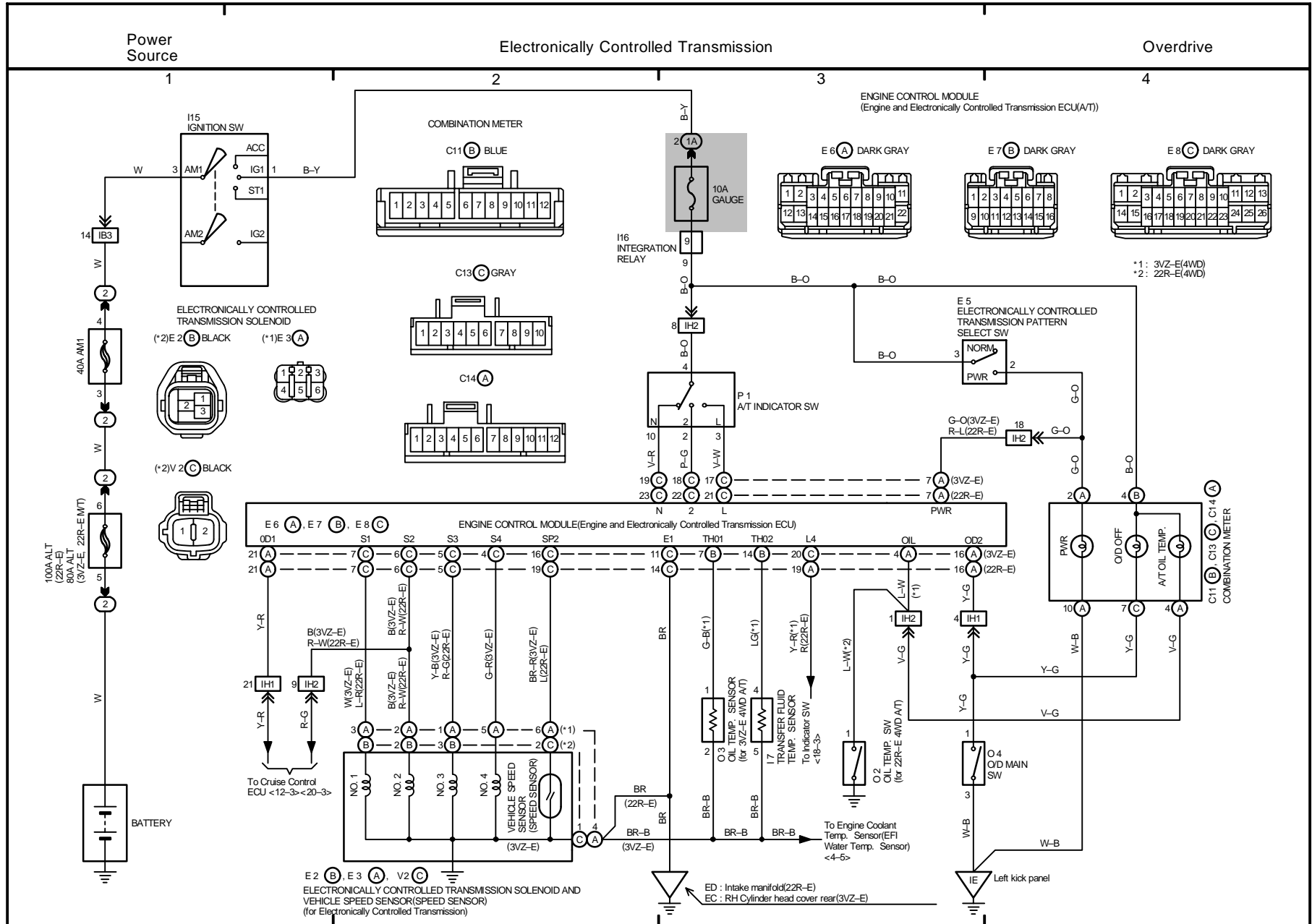

# OVERALL ELECTRICAL WIRING DIAGRAM

9 4RUNNER

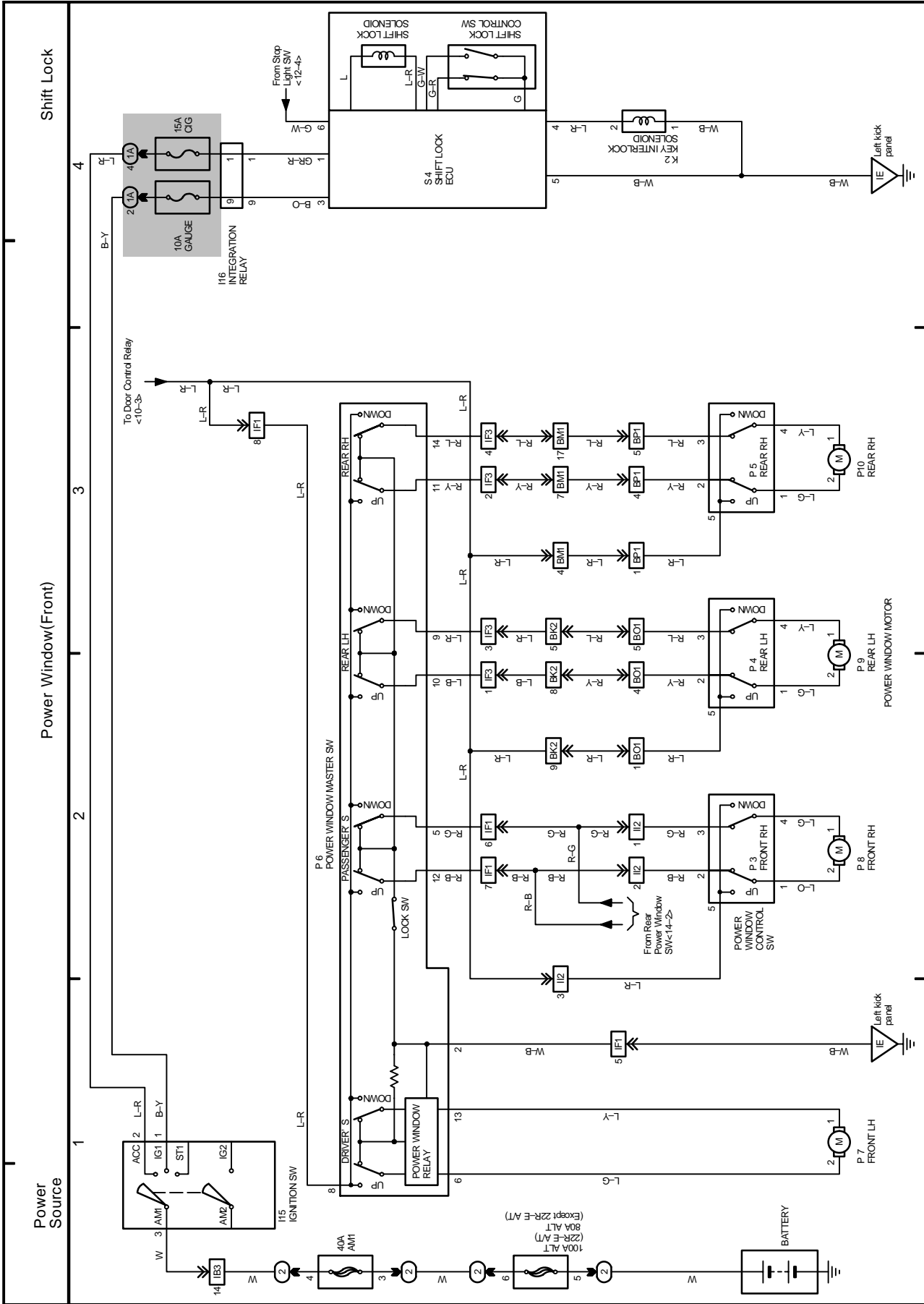

# 10 4RUNNER

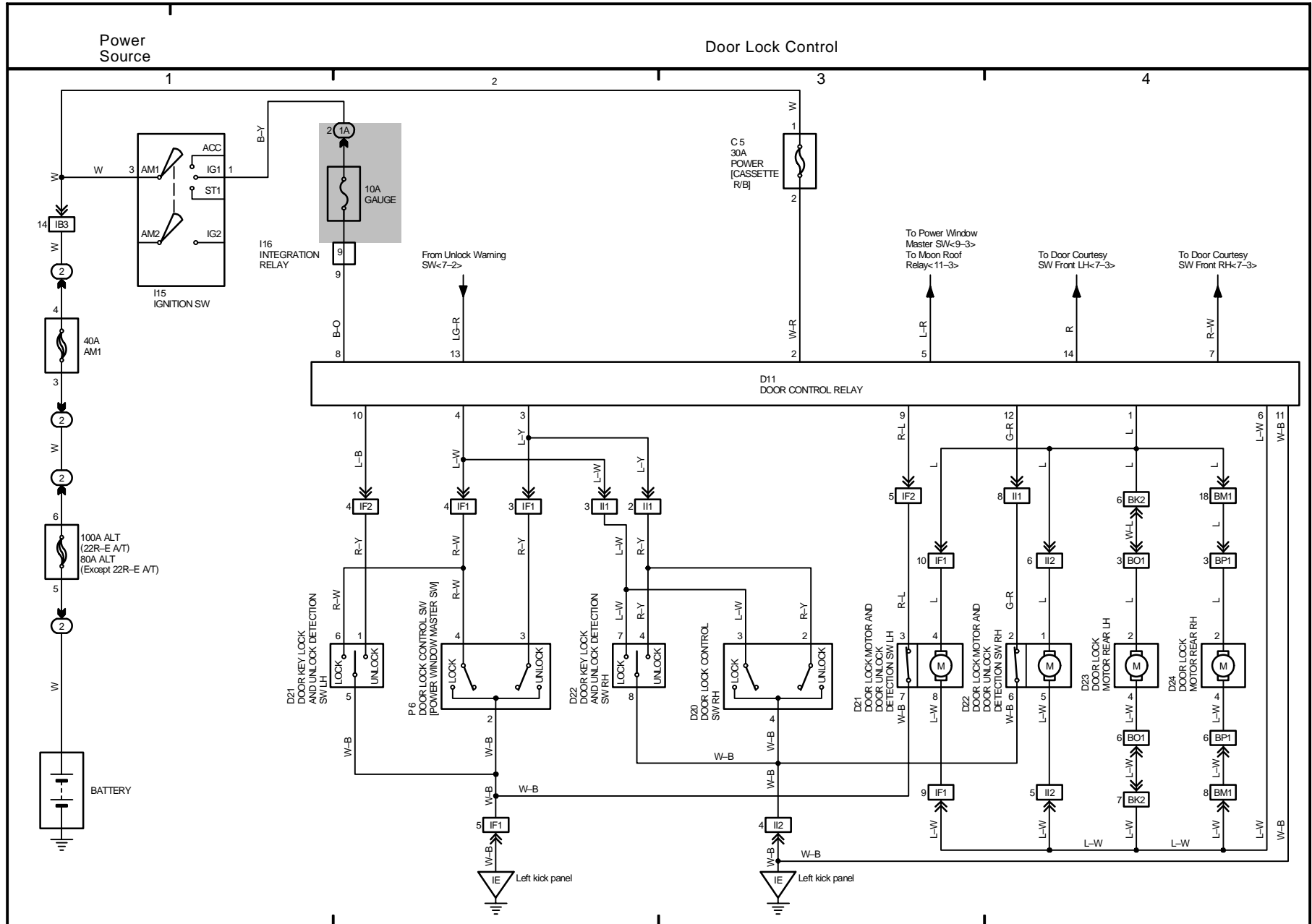





# OVERALL ELECTRICAL WIRING DIAGRAM

## 13 4RUNNER

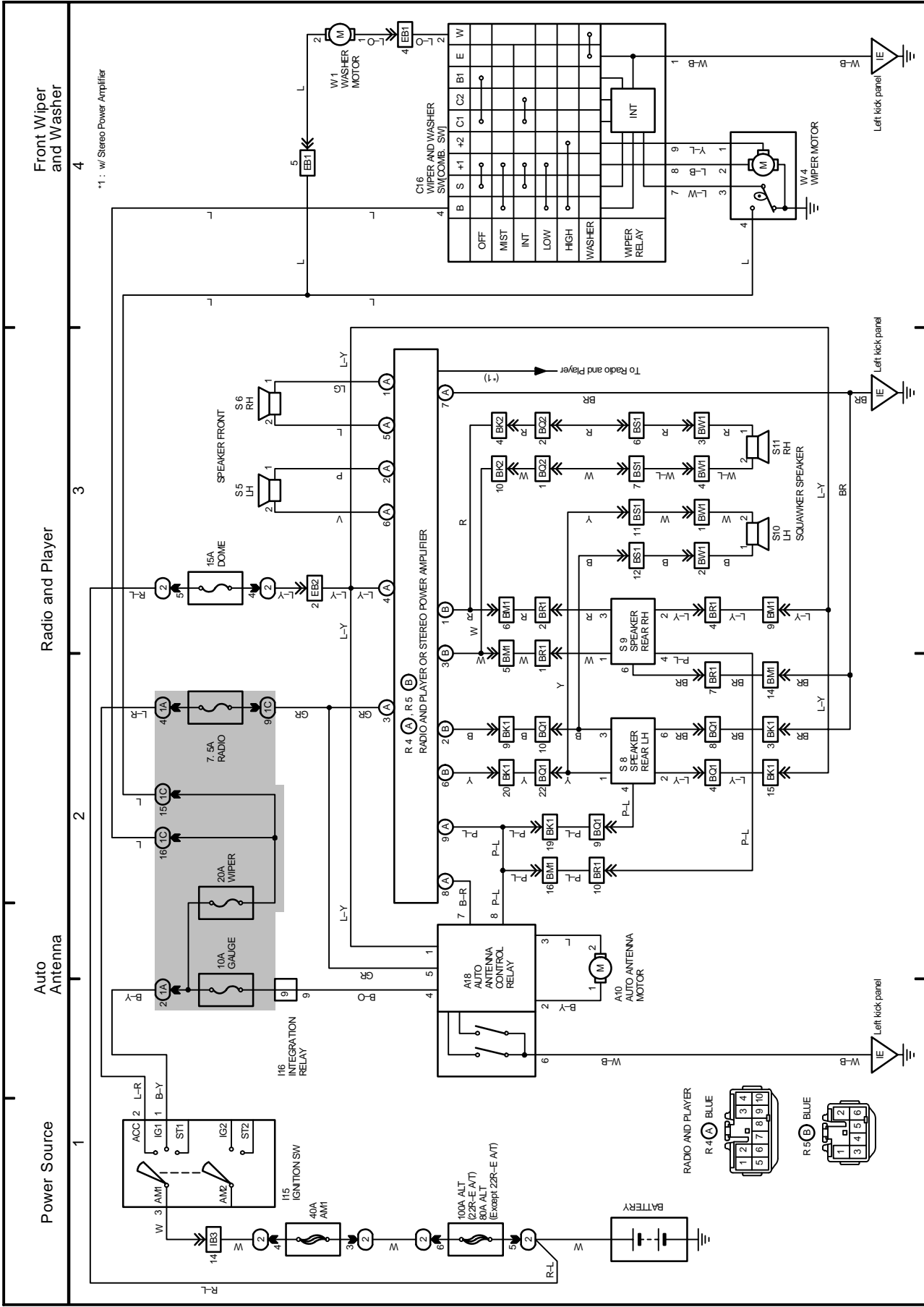

# 14 4RUNNER

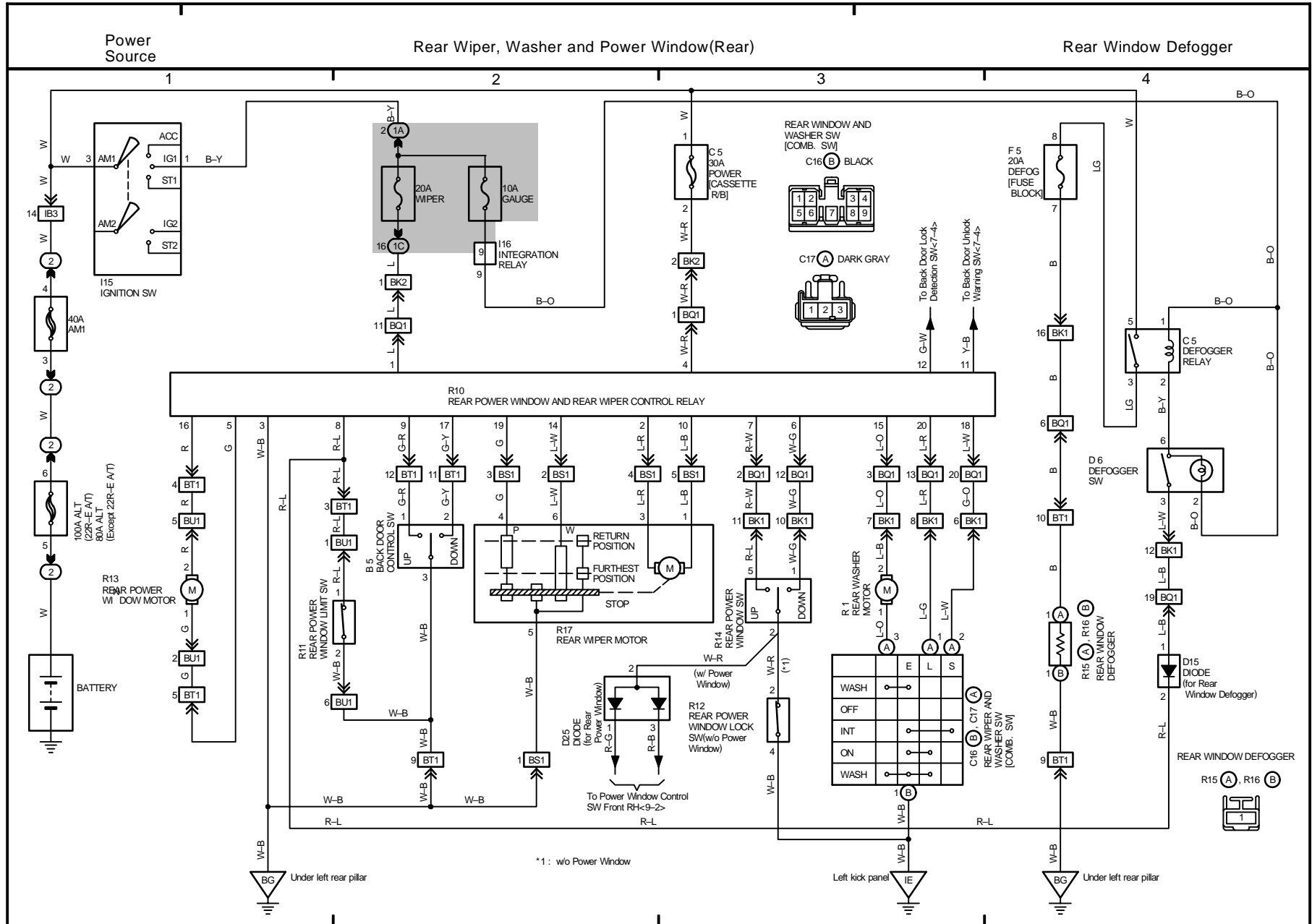



# 16 4RUNNER

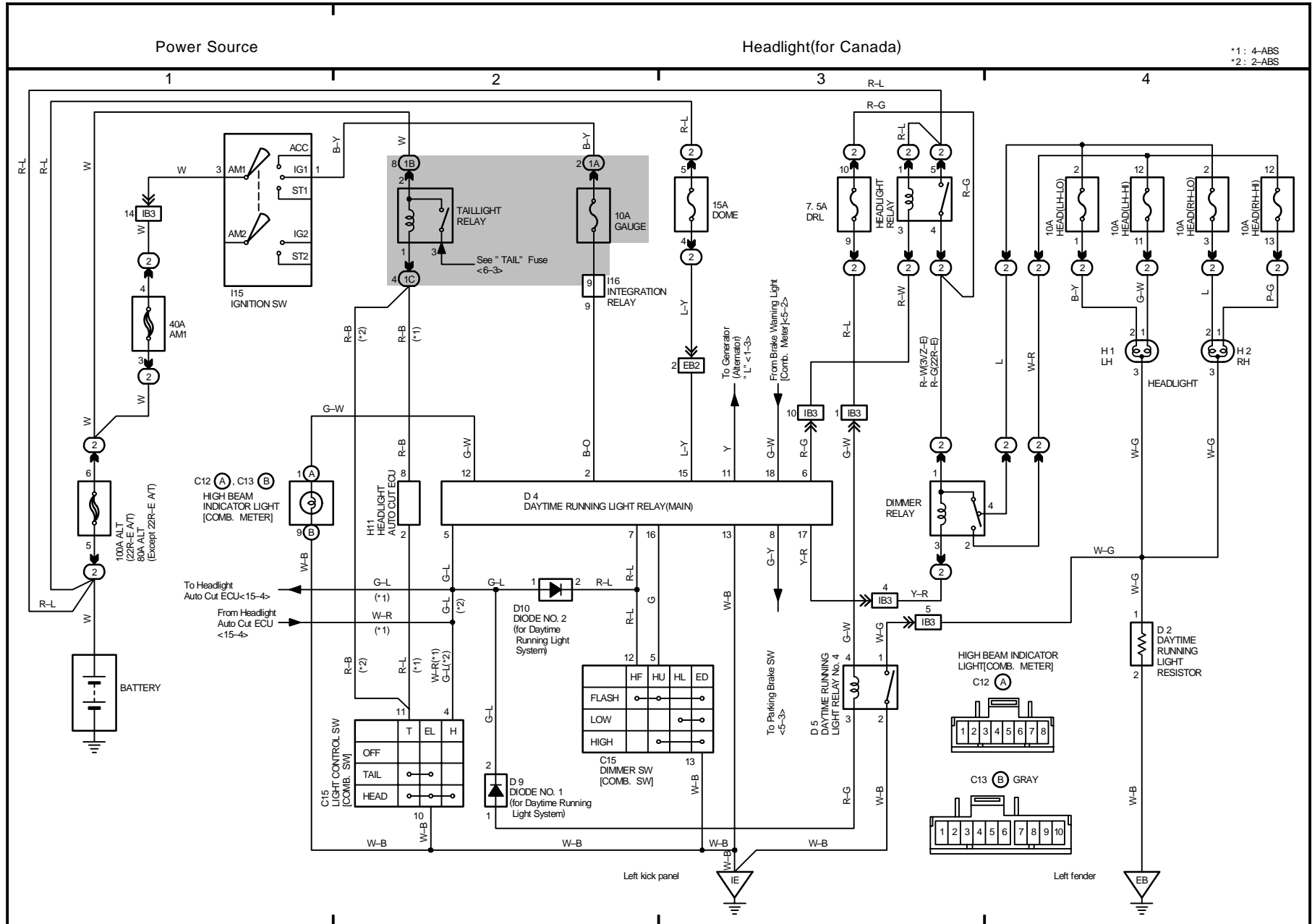

# OVERALL ELECTRICAL WIRING DIAGRAM

## 17 4RUNNER

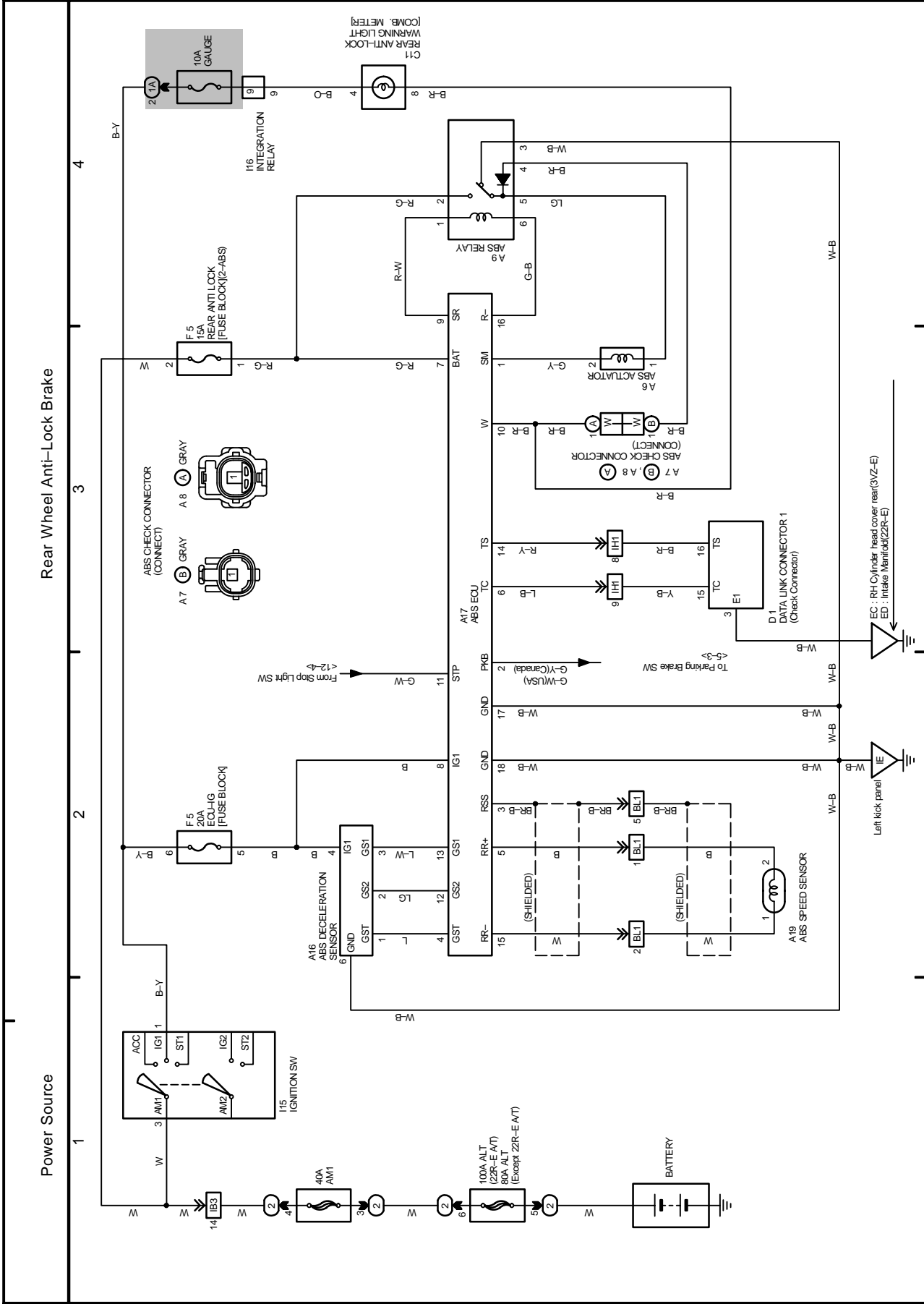

# 18 4RUNNER

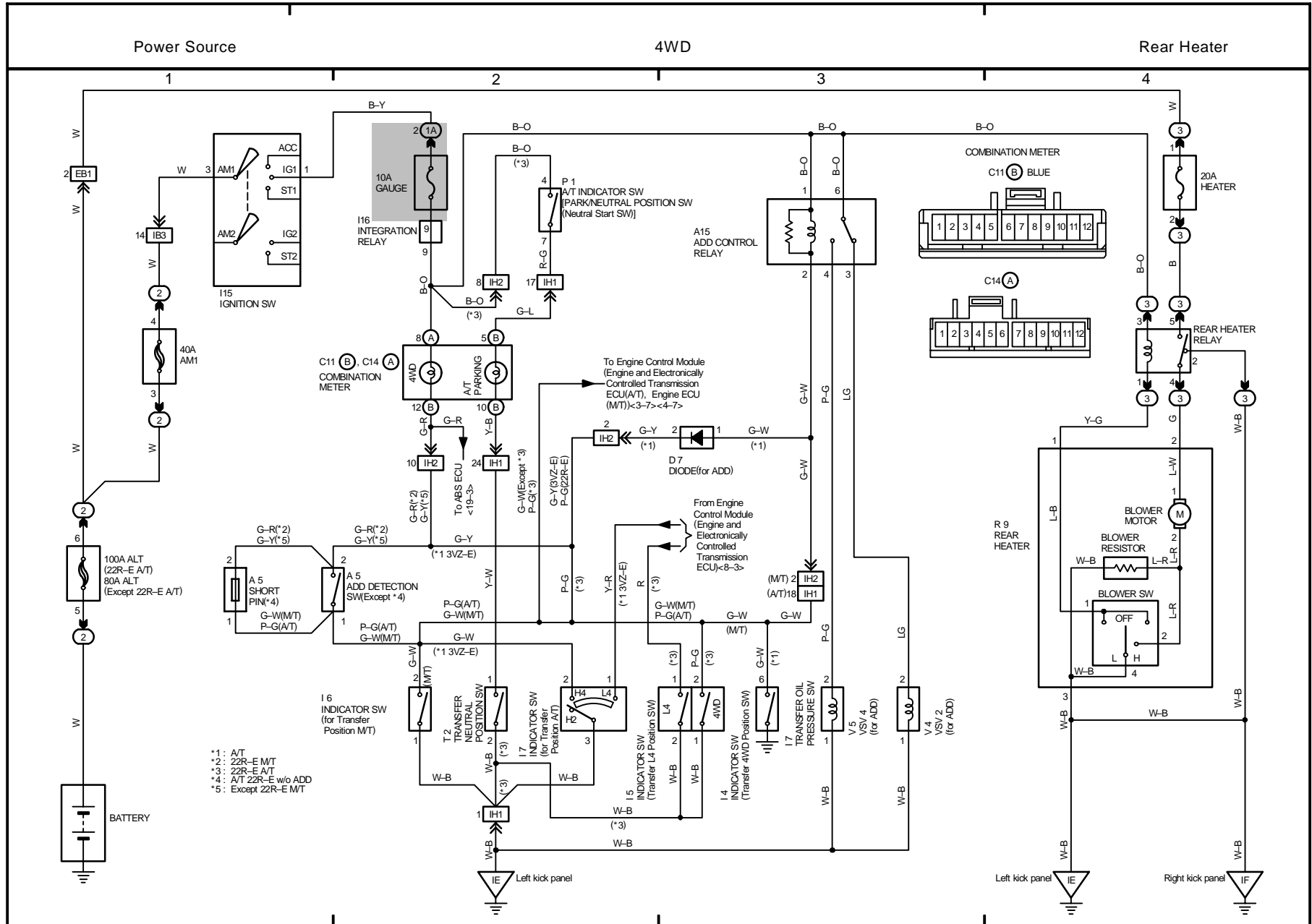

# OVERALL ELECTRICAL WIRING DIAGRAM

## 19 4RUNNER

### ABS (Anti-Lock Brake System)

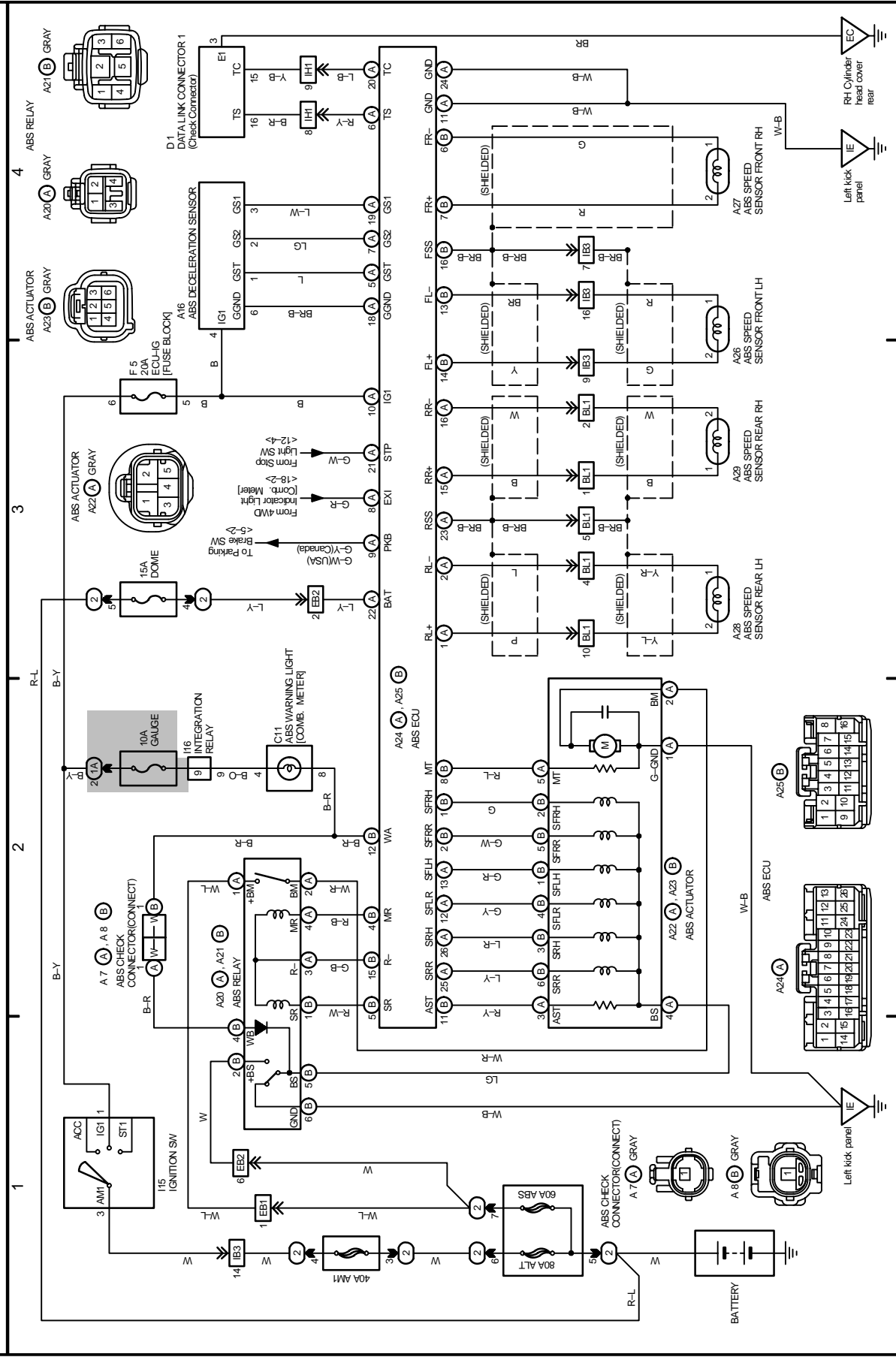

# 20 4RUNNER

