

INSTALLATION

1. INSTALL CLUTCH DISC AND CLUTCH COVER ON FLYWHEEL

- (a) Insert the SST in the clutch disc, and then set them.
SST 09301-00110

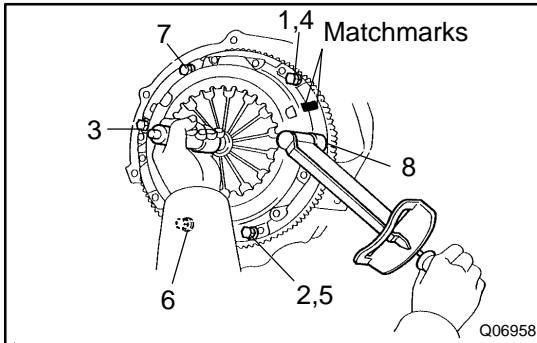

- (b) Align the matchmarks on the clutch cover and flywheel.
(c) Torque the 6 bolts on the clutch cover in the order shown.

Torque: 19 N·m (195 kgf·cm, 14 ft·lbf)

HINT:

Temporarily tighten the No.1 and No.2 bolts.

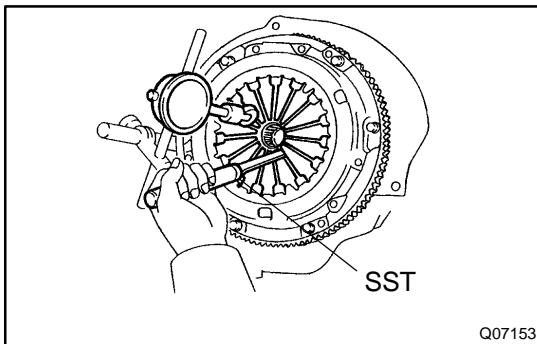

2. CHECK DIAPHRAGM SPRING TIP ALIGNMENT

Using a dial indicator with roller instrument, check the diaphragm spring tip alignment.

Maximum non-alignment: 0.5 mm (0.020 in.)

If alignment is not as specified, using SST, adjust the diaphragm spring tip alignment.

SST 09333-00013

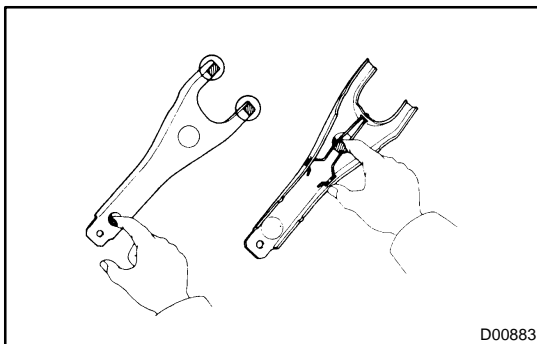

3. APPLY MOLYBDENUM DISULPHIDE LITHIUM BASE GREASE (NLGI NO.2)

- (a) Apply release hub grease to these parts:
- Release fork and hub contact point
 - Release fork and push rod contact point
 - Release fork pivot point

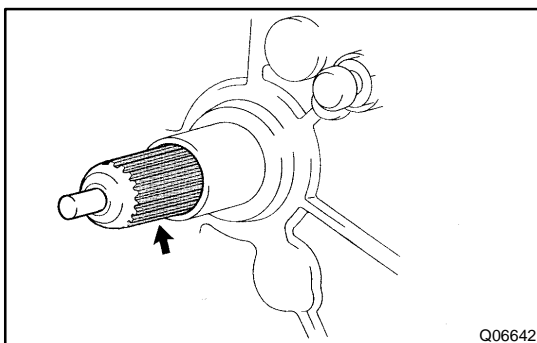

- (b) Apply clutch spline grease.

- Clutch disc spline

HINT:

Recommended grease part number 08887-01706 (100 g).

4. INSTALL BOOT, RELEASE BEARING AND FORK TO TRANSMISSION

Install the boot and bearing to the release fork, and then install them to the transmission.

5. INSTALL TRANSMISSION TO ENGINE

- W59 M/T(2WD): See page MT-3
- W59 M/T(4WD): See page MT-8
- R150 M/T: See page MT-3
- R150F M/T: See page MT-7